

**KNOWLEDGE
FOR A BRIGHTER
FUTURE**

Properties and applications of Ni-Resist and ductile Ni-Resist alloys

A PRACTICAL GUIDE TO THE USE
OF NICKEL-CONTAINING ALLOYS
N° 11018

Properties and applications of Ni-Resist and ductile Ni-Resist alloys (11018)

A GUIDE TO THE USE OF NICKEL-CONTAINING ALLOYS

SECOND EDITION
Published 2022

The material presented in this publication has been prepared for the general information of the reader and should not be used or relied on for specific applications without securing competent advice.

The Nickel Institute, its members, staff and consultants do not represent or warrant its suitability for any general or specific use and assume no liability or responsibility of any kind in connection with the information herein.

Updated by Dr. John Fischer, Consultant to the Nickel Institute

Edited by Geir Moe

Cover Photo H. Downs

Contents

Introduction – Properties and characteristics of Ni-Resist austenitic cast iron alloy	5
Part I – The alloys	6
Flake graphite alloys	7
Spheroidal graphite alloys	8
Effect of composition on structure and properties ..	9
Mechanical properties	10
Physical properties	11
Properties affecting design and manufacture . . .	13
Heat treatment	13
Welding	14
Properties affecting service performance	15
Wear and galling resistance	15
Corrosion resistance	15
Elevated temperature performance	20
Low temperature performance	24
Advantages and applications of the physical properties of Ni-Resist alloys	24
Thermal expansion	24
Fields of application	25
Part II – National and international standards . . .	32
Comparison of international and national standards covering austenitic cast iron	32
Part III – Corrosion data	34
Selected bibliography	60

Properties and applications of Ni-Resist and ductile Ni-Resist Alloys

INTRODUCTION

PROPERTIES AND CHARACTERISTICS OF NI-RESIST AUSTENITIC CAST IRON ALLOYS

There are two families of Ni-Resist austenitic cast irons. These are the standard or flake graphite alloys and the ductile or spheroidal graphite alloys. As time passes, the spheroidal grades, because of higher strength, ductility and elevated temperature properties, are becoming more prominent. However, the flake materials with lower cost, fewer foundry problems and better machinability and thermal conductivity are still produced by many foundries. General characteristics of both groups are described below.

Corrosion resistance: The Ni-Resists are specified for handling salt solutions, seawater, mild acids, alkalies and oil field liquids, both sweet and sour. Their corrosion resistance is far superior to that of the unalloyed grey and ductile (SG) cast irons. They are not stainless steels and do not behave as such. They are characterised by uniform corrosion rather than by localised deterioration.

Wear resistance: Cylinder liners, pistons, wear rings and sleeves, bearings, glands and other metal-to-metal rubbing parts are cast in Ni-Resist alloys. Their galling resistance is excellent.

Erosion resistance: Slurries, wet steam and other fluids with entrained solids are substances which are extremely erosive to most metals. Ni-Resist alloys offer a combination of erosion-corrosion resistance which is superior in these environments. They are outstanding when compared to grey cast iron, ductile irons and steel.

Toughness and low temperature stability: Ni-Resist alloys are much superior to grey cast irons, particularly at low temperatures.

Controlled expansion: Coefficient of expansion as low as 5.0×10^{-6} to as high as 18.7×10^{-6} cm/cm/°C (2.8×10^{-6} to 10.4×10^{-6} in/in/°F) are possible with the different Ni-Resist alloys. The lower value makes possible a cast metal with a low expansion rate for precision parts. Also, the range permits matching Ni-Resists with many different metals and alloys.

Magnetic and electrical properties: Some Ni-Resist alloys are non-magnetic. These and others have high electrical resistance. Thus, they are used for resistance grids, electric furnace parts, in clutches and other applications requiring these properties combined with machinability and heat resistance.

Heat resistance: Originally, because of good heat and oxidation resistance, the flake graphite Ni-Resist alloys were used at temperatures up to 700 °C (1300 °F). However, because of the superior elevated temperature properties of the spheroidal graphite Ni-Resists, the flake alloys are now seldom used above 315 °C (600 °F). Spheroidal graphite Ni-Resist alloys can be and are used at temperatures up to 1050 °C (1930 °F). Although the ductile alloys are better, all Ni-Resists have relatively low rates of oxidation in air. The resulting oxides adhere tenaciously, further reducing oxidation with time.

Machinability: The machining techniques possible for Ni-Resist castings are similar to those for the higher strength grades of grey cast iron and austenitic stainless steels.

Castability: Complicated and intricate designs that are often difficult to cast in other materials are possible with Ni-Resist alloys. This leads to products that are economically produced.

PART I THE ALLOYS

The Ni-Resist cast irons are a family of alloys with enough nickel to produce an austenitic structure which has unique and superior properties. The family is divided into two groups. These are the standard or flake graphite alloys and the ductile or spheroidal graphite alloys. Except for the copper-containing ones, the groups have materials similar in composition but for a magnesium addition which converts the graphite to the spheroidal form in the ductile Ni-Resists. Copper interferes with the magnesium treatment and alloys high in copper cannot be produced with spheroidal graphite. Typical micro-structures of flake and spheroidal graphite alloys are shown in *Figures 1* and *2*, respectively.

Figure 1 Typical Microstructure of Flake Graphite Ni-Resist Alloys – Ni-Resist 1- Graphite Flakes and Carbide Areas within Austenite Matrix

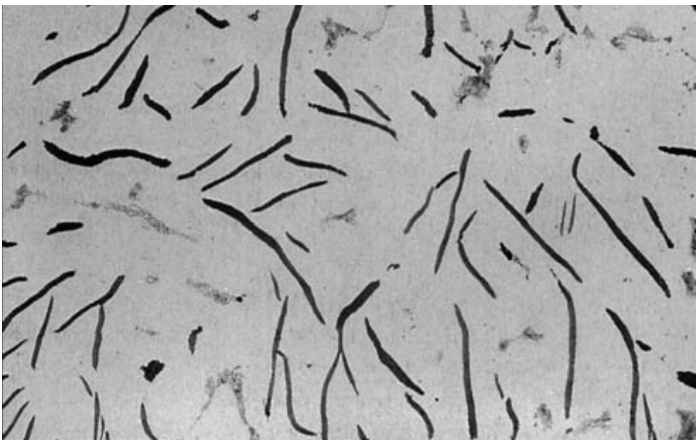

The composition and properties of the Ni-Resists have been covered by several national and international specifications. The nomenclature describing these alloys varies from country to country. *Tables 1* and *2* give the common name for the various alloys and their designations in four different specifications. The specifying bodies in these tables are the American Society for Testing and Materials (ASTM), the International Organization for Standardization (ISO), Euronorm (EN) and the Japanese Industrial Standards (JIS). Other national designations which have been withdrawn are shown in Part II. Nominal chemical compositions are shown in *Tables 3* and *4*. Refer to Part II for detailed composition ranges in accordance with ASTM, ISO and EN specifications and with the current national or international specifications for current composition requirements.

Figure 2 Typical Microstructure of Spheroidal Graphite Ni-Resist Alloys – Ni-Resist D-2W – Graphite Spheres and Carbide Areas within Austenite Matrix

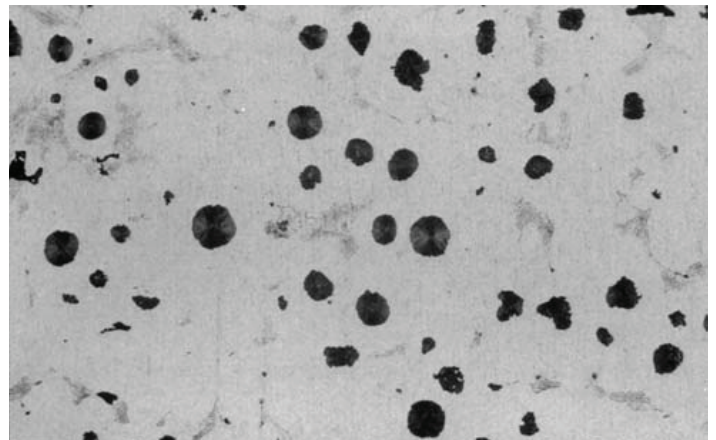

Table 1 Typical nomenclatures for flake graphite Ni-Resist alloys

Common name	ASTM A436-84(2020) (UNS)	ISO 2892-2007	EN 13835-2012	JIS G 5510:2012
NiMn 13 7	-	L-NiMn 13 7	GJLA-XNiMn 13 7	FCA-NiMn 13 7
Ni-Resist 1	Type 1 (F41000)	L-NiCuCr 15 6 2	GJLA-XNiCuCr 15 6 2	FCA-NiCuCr 15 6 2
Ni-Resist 1b	Type 1b (F41001)	L-NiCuCr 15 6 3	-	FCA-NiCuCr 15 6 3
Ni-Resist 2	Type 2 (F41002)	L-NiCr 20 2	-	FCA-NiCr 20 2
Ni-Resist 2b	Type 2b (F41003)	L-NiCr 20 3	-	-
Nicrosilal	-	L-NiSiCr 20 5 3	-	FCA-NiSiCr 20 5 3
Ni-Resist 3	Type 3 (F41004)	L-NiCr 30 3	-	-
Ni-Resist 4	Type 4 (F41005)	L-NiSiCr 30 5 5	-	FCA-NiSiCr 30 5 5
Ni-Resist 5	Type 5 (F41006)	L-Ni 35	-	FCA-Ni 35
Ni-Resist 6	Type 6 (F41007)	-	-	-

FLAKE GRAPHITE ALLOYS

Ni-Resist NiMn 13 7 – Relatively low cost, non-magnetic alloy is not used where corrosion and/or high temperature resistance are required.

Ni-Resist 1 – Good resistance to corrosion in alkalis, dilute acids, seawater and other salt solutions and has good

moderate temperature and wear resistance. Used for pumps, valves and products where wear resistance is required. Used for piston ring inserts because of matching expansion characteristics with aluminium piston alloys.

Ni-Resist 1b – Similar applications as Ni-Resist 1 but has superior erosion-corrosion resistance. Higher chromium content produces an alloy that is harder and stronger.

Table 2 Typical nomenclatures for spheroidal graphite Ni-Resist alloys

Common name	ASTM A439-18 (UNS)	ISO 2892-2007	EN 13835-2012	JIS G 5510:2012
Ni-Resist D-2	Type D-2 (F43000)	S-NiCr 20 2	GJSA-XNiCr 20 2	FCDA-NiCr 20 2
Ni-Resist D-2W	-	-	GJSA-XNiCrNb 20 2	FCDA-NiCrNb 20 2
Ni-Resist D-2B	Type D-2B (F43001)	S-NiCr 20 3	-	FCDA-NiCr 20 3
Nicrosilal Spheronic	-	S-NiSiCr 20 5 2	-	-
Ni-Resist D-2C	Type D-2C (F43002)	S-Ni 22	GJSA-XNi 22	FCDA-Ni 22
Ni-Resist D-2M	Type D-2M (F43010)	S-NiMn 23 4	GJSA-XNiMn 23 4	FCDA-NiMn 23 4
Ni-Resist D-2S	Type D-2S	-	-	-
Ni-Resist D-3	Type D-3 (F43003)	S-NiCr 30 3	GJSA-XNiCr 30 3	FCDA-NiCr 30 3
Ni-Resist D-3A	Type D-3A (F43004)	S-NiCr 30 1	-	FCDA-NiCr 30 1
Ni-Resist D-4	Type D-4 (F43005)	S-NiSiCr 30 5 5	GJSA-XNiSiCr 30 5 5	FCDA-NiSiCr 30 5 5
Ni-Resist D-4A	-	-	-	-
Ni-Resist D-5	Type D-5 (F43006)	S-Ni 35	GJSA-XNi 35	FCDA-Ni 35
Ni-Resist D-5B	Type D-5B (F43007)	S-NiCr 35 3	GJSA-XNiCr 35 3	FCDA-NiCr 35 3
Ni-Resist D-5S	Type D-5S	S-NiSiCr 35 5 2	GJSA-XNiSiCr 35 5 2	FCDA-NiSiCr 35 5 2
Ni-Resist D-6	-	S-NiMn 13 7	GJSA-XNiMn 13 7	FCDA-NiMn 13 7

Table 3 Nominal compositions of flake graphite Ni-Resist alloys*, wt.%

Common name	C, max.	Ni	Cr	Si	Cu	Mn	Other
NiMn 13 7 **	3.0	13.0	0.2 max.	2.0	-	6.5	-
Ni-Resist 1	3.0	15.5	2.0	1.9	6.5	1.0	-
Ni-Resist 1b	3.0	15.5	3.0	1.9	6.5	1.0	-
Ni-Resist 2	3.0	20.0	2.0	1.9	0.50 max.	1.0	-
Ni-Resist 2b	3.0	20.0	4.5	1.9	0.50 max.	1.0	-
Nicrosilal **	2.5	20.0	3.0	4.5	-	1.0	-
Ni-Resist 3	2.6	30.0	3.0	1.5	0.50 max.	1.0	-
Ni-Resist 4	2.6	30.5	5.0	5.5	0.50 max.	1.0	-
Ni-Resist 5	2.4	35.0	0.1 max.	1.5	0.50 max.	1.0	-
Ni-Resist 6	3.0	20.0	1.5	3.0	4.5	1.0	1.0 Mo max.

*ASTM A436, single values are maximums ** not listed in ASTM A436

Table 4 Nominal compositions of spheroidal graphite Ni-Resist alloys*, wt.%

Common name	C, max.	Ni	Cr	Si	Mn	Other
Ni-Resist D-2	3.0	20.0	2.2	2.0	1.0	-
Ni-Resist D-2W **	3.0	20.0	1.8	1.8	1.0	0.16 Nb
Ni-Resist D-2B	3.0	20.0	3.3	2.2	1.0	-
Nicrosilal Spheronic **	3.0	20.0	1.7	5.0	0.7	-
Ni-Resist D-2C	2.9	22.5	0.5	2.0	2.1	-
Ni-Resist D-2M ***	2.2–2.7	22.5	0.2	2.0	4.1	-
Ni-Resist D-2S	2.6	26.0	2.0	5.3	1.0	-
Ni-Resist D-3A	2.6	30.0	1.2	1.9	1.0	-
Ni-Resist D-3	2.6	30.0	3.0	1.9	1.0	-
Ni-Resist D-4A	2.6	30.0	2.0	5.0	1.0	-
Ni-Resist D-4	2.6	30.0	5.0	5.5	1.0	-
Ni-Resist D-5	2.4	35.0	0.1 max.	1.9	1.0	-
Ni-Resist D-5B	2.4	35.0	2.5	1.9	1.0	-
Ni-Resist D-5S	2.3	35.5	1.7	5.2	1.0	-
Ni-Resist D-6 *	3.0	13.0	0.2 max.	2.5	6.5	-

* ASTM A439; ** not listed in ASTM A439; *** ASTM A571

Ni-Resist 2 – Higher nickel content makes this alloy more corrosion resistant in alkaline environments. Has found applications for handling soap, food products, rayon and plastics. Used where freedom from copper contamination is required.

Ni-Resist 2b – Greater hardness improves erosion-corrosion resistance. This alloy performs well in metal-to-metal wear situations.

Nicrosilal – Has improved corrosion resistance in dilute sulphuric acid. Used for pumps, valves and other castings requiring higher mechanical properties.

Ni-Resist 3 – Has resistance to corrosion in wet steam and corrosive slurries. Can be used where it is necessary to match the coefficient of expansion of grey cast iron or steel at temperatures around 260 °C (500 °F). Applications include pumps, valves and machinery castings.

Ni-Resist 4 – Has excellent stain resistance. Is superior to other Ni-Resist alloys with regard to erosion-corrosion resistance.

Ni-Resist 5 – Has lowest coefficient of thermal expansion of Ni-Resist alloys. Provides dimensional stability for machine tool parts, forming dies, instruments and expansion joints.

Ni-Resist 6 – Is an uncommon alloy. When produced, it is used for pumps and valves handling corrosive solutions. Is not related to Ni-Resist D-6.

SPHEROIDAL GRAPHITE ALLOYS

Ni-Resist D-2 – Has good resistance to corrosion, erosion-corrosion and frictional wear. Can be used at temperatures up to 760 °C (1400 °F). Applications are pumps, valves, compressors, turbocharger housings and exhaust gas manifolds used with Ni-Resist D-2W, a primary ductile grade.

Ni-Resist D-2W – Has similar properties and applications as Ni-Resist D-2, but with better weldability when proper procedures are followed.

Ni-Resist D-2B – Has higher chromium content which results in better corrosion and erosion-corrosion resistance than Ni-Resist D-2. Has similar applications to Ni-Resist D-2.

Nicrosil Spheronic and D-2S – Has improved corrosion resistance in dilute sulphuric acid. It has good high temperature stability and improved oxidation resistance and high temperature strength. It is used for pumps, valves and other castings requiring higher mechanical properties.

Ni-Resist D-2C – Used for pumps, valves, compressors and turbocharger parts where high ductility is desired. Because of good resistance to wet steam erosion, another important application is in steam turbines. Sometimes used for non-magnetic components. Is also used for some low temperature applications.

Ni-Resist D-2M – Maintains ambient temperature mechanical properties down to -170 °C (-275 °F). Major uses are for refrigeration and cryogenic equipment.

Ni-Resist D-3A – Suggested where a high degree of wear and galling resistance are required along with moderate amounts of thermal expansion.

Ni-Resist D-3 – Has good corrosion resistance at elevated temperatures. Excellent erosion-corrosion resistance in wet steam and salt slurries. Uses include pumps, valves, filter parts, exhaust gas manifolds and turbocharger housings.

Ni-Resist D-4A – Has excellent corrosion and erosion-corrosion resistance with superior high temperature properties. Finds uses in pumps, armatures, exhaust gas piping and turbocharger parts.

Ni-Resist D-4 – Corrosion, erosion-corrosion and heat resistant properties are superior to those of Ni-Resists D-2 and D-3. Applications are similar to Ni-Resist D-4A.

Ni-Resist D-5 – Is used where low thermal expansion is required. Applications include machine tool parts, scientific instruments and glass molds.

Ni-Resist D-5B – Has low thermal expansion with high levels of heat and corrosion resistance. Has good mechanical properties at elevated temperatures. Used for low pressure gas turbine housings, glass molds and other elevated temperature applications.

Ni-Resist D-5S – Has excellent resistance to growth and oxidation at temperatures up to 1050 °C (1930 °F). Low coefficient of thermal expansion with good thermal shock resistance. Used in gas turbines, turbocharger housings, exhaust manifolds and hot-pressing dies.

Ni-Resist D-6 – Is non-magnetic with good mechanical properties. Used for switch insulator flanges, terminals, ducts and turbine generator parts. Type D-6 is a spheroidal graphite variation of the flake alloy Ni-Resist NiMn 13 7.

EFFECT OF COMPOSITION ON STRUCTURE AND PROPERTIES

Each of the alloying elements in the iron base of the Ni-Resists affects the structure and/or properties in different ways. The intentional additions make important and necessary contributions. The following is a brief synopsis of the unique effects of these substances.

Nickel

Nickel is the element which gives the Ni-Resist alloys their defining characteristics. It is primarily responsible for the stable austenitic structure and makes substantial contributions to corrosion and oxidation resistance and to mechanical properties throughout the usable temperature range. The coefficient of thermal expansion is also largely dependent on the nickel content, reaching a minimum at 35% nickel.

Chromium

The most important effects of chromium are improvements in strength and corrosion resistance at elevated temperatures. It also causes increased hardness which improves wear and erosion-corrosion resistance. Chromium decreases ductility by forming a higher percentage of hard carbides. Higher chromium can lead to a greater propensity for micro-porosity in castings.

Copper

Copper improves corrosion resistance in mildly acidic solutions. It interferes with the magnesium treatment used to produce spheroidal graphite and cannot be added to ductile Ni-Resists.

Carbon

Carbon is a characteristic element in all cast irons. High carbon reduces the solidification temperature and improves the melting and pouring behaviour. Lower carbon contents usually lead to fewer carbides and higher strength and toughness.

Silicon

Silicon is another essential element in cast irons. It improves fluidity of the melt which leads to better casting properties, especially for thin-walled sections. Silicon also contributes to greater high temperature corrosion resistance. This element lessens chromium carbide formation.

Manganese

Manganese provides no improvements in corrosion resistance, high-temperature or mechanical properties. However, it is an austenite stabiliser which makes important contributions to the low temperature properties of Ni-Resist D-2M and to the non-magnetic alloys such as Ni-Resist NiMn 13 7.

Niobium (Columbium)

Niobium is an important addition agent which leads to the improved weldability of Ni-Resist D-2W. Control of silicon, sulphur and phosphorous are also necessary for maximum effect. It will probably have similar effects in other compositions.

Molybdenum

Molybdenum is not specified in the various grades of Ni-Resist alloys, but about 2% is sometimes added for improved high temperature strength.

Magnesium

A necessary ladle addition which leads to the formation of spheroidal graphite in the ductile Ni-Resists. Only a very small quantity is present in castings.

MECHANICAL PROPERTIES

Tables 5 and 6 list the nominal mechanical properties for flake and spheroidal graphite Ni-Resist alloys, respectively. These are average values given for guidance only. Actual specification values are given in Part II. In general, these are for as-cast material. Mechanical properties can be varied by heat treatment and by altering the levels of carbon, silicon, chromium and, if desired, molybdenum. For unique service requirements, special agreements on composition and properties can often be reached between buyer and producer.

Tensile strength

The tensile strengths of the flake graphite alloys have only a minor variation, because the austenitic matrix common to all alloys largely controls the strength level. Some variation in strength is however possible by controlling the size, amount and distribution of graphite flakes through heat treatment. It is also possible to raise strength levels by lowering carbon and silicon and/or raising chromium.

The tensile strengths of the spheroidal graphite alloys, except for Ni-Resist D-2M, are about the same, although at significantly higher values than for the flake graphite materials. This similarity is again caused by the common austenite matrix. Strength values can also be varied by similar compositional changes as mentioned above for the flake graphite alloys. The 0.2% offset yield strengths are also about the same for the spheroidal graphite alloys, except for Ni-Resist D-2C and D-4 where it is lower and higher, respectively.

Table 5 Typical mechanical properties of flake graphite Ni-Resist alloys

Common name	Tensile strength MPa (ksi)	Compressive strength MPa (ksi)	Elongation %	Modulus of elasticity GPa (10 ⁶ psi)	Brinell hardness (HB)
NiMn 13 7	140-220 (20-31)	630-840 (90-120)	-	70-90 (10-13)	120-150
Ni-Resist 1	170-210 (24-30)	700-840 (100-120)	2	85-105 (12-15)	120-215
Ni-Resist 1b	190-240 (27-34)	860-1100 (123-157)	1-2	98-113 (14-16)	150-250
Ni-Resist 2	170-210 (24-30)	700-840 (100-120)	2-3	85-105 (12-15)	120-215
Ni-Resist 2b	190-240 (27-34)	860-1100 (123-157)	1-2	98-113 (14-16)	160-250
Nicrosilal	190-280 (27-40)	-	2-3	-	140-250
Ni-Resist 3	190-240 (27-34)	700-910 (100-130)	1-3	98-113 (14-16)	120-215
Ni-Resist 4	170-240 (24-34)	560 (80)	-	105 (15)	150-210
Ni-Resist 5	120-180 (17-26)	560-700 (80-100)	1-3	74 (11)	120-140
Ni-Resist 6	170-210 (24-30)	700-840 (100-120)	-	-	130-180

Elongation (ductility)

As seen in *Tables 5* and *6*, elongation values for the spheroidal graphite varieties are significantly higher than for the flake graphite alloys. This is also true when comparing the spheroidal types to unalloyed flake graphite grey cast irons. Higher chromium content will lower ductility in the spheroidal graphite alloys because of an increased number of carbides in the austenitic matrix. Changing the carbide content through heat treatment can also affect elongation values.

Modulus of elasticity

The moduli of elasticity of the Ni-Resist alloys are similar to those for unalloyed grey cast irons. For alloys of similar composition, the values are slightly, but not significantly, higher for ductile Ni-Resists. Typical values are given in *Tables 5* and *6* and in the specifications in Part II.

Impact strength

The impact resistance of flake graphite Ni-Resist alloys are higher than those of grey cast iron but still quite low compared to spheroidal graphite Ni-Resist. They are usually

not included in specifications. Charpy V-notch values for spheroidal graphite Ni-Resists are much higher. Typical values are given in *Table 6* and some of the mechanical property tables in the specifications in Part II. Chromium content has a marked effect on impact strength with low or chromium-free alloys having higher values. The impact resistance decreases as temperature drops to sub-zero levels, but, because of the austenitic structure, there is no sharp embrittlement or transition point. In the case of Ni-Resist D-2M, the impact strength is maintained to -196 °C (-321 °F).

PHYSICAL PROPERTIES

Tables 7 and *8* list the average physical properties for flake and spheroidal graphite alloys: Density, Thermal expansion, Thermal conductivity, Electrical resistivity and Magnetic permeability.

Density

As can be seen from the tables, the density of the various Ni-Resist alloys is about the same, except for Ni-Resists D-5 and D-5B. Generally, the density of Ni-Resists is about 5% higher than for grey cast iron and 15% lower than cast bronze alloys.

Table 6 Typical mechanical properties of spheroidal graphite Ni-Resist alloys

Common name	Tensile strength MPa (ksi)	Compressive strength MPa (ksi)	Elongation %	Modulus of elasticity GPa (10 ⁶ psi)	Charpy impact J (ft-lbf)	Brinell hardness (HB)
Ni-Resist D-2	370-480 (53-69)	210-250 (30-36)	7-20	112-130 (16-19)	16 (12)	140-200
Ni-Resist D-2W	370-480 (53-69)	210-250 (30-36)	8-20	112-130 (16-19)	-	140-200
Ni-Resist D-2B	390-500 (56-71)	210-260 (30-37)	7-15	112-133 (16-19)	13 (10)	150-255
Nicrosilal Spheronic	370-440 (53-63)	210-260 (30-37)	10-18	-	-	180-230
Ni-Resist D-2C	370-450 (53-64)	170-250 (24-36)	20-40	85-112 (12-16)	38 (28)	130-170
Ni-Resist D-2M	440-480 (63-69)	210-240 (30-34)	25-45	120-140 (17-20)	38 (28)	150-180
Ni-Resist D-3A	370-450 (53-64)	210-270 (30-39)	13-18	112-130 (16-19)	19 (14)	130-190
Ni-Resist D-3	370-480 (53-69)	210-260 (30-37)	7-18	92-105 (13-15)	9 (7)	140-200
Ni-Resist D-4A	380-500 (54-71)	210-270 (30-39)	10-20	130-150 (19-21)	-	130-170
Ni-Resist D-4	390-500 (56-71)	240-310 (34-44)	1-4	90 (13)	-	170-250
Ni-Resist D-5	370-420 (53-60)	210-240 (30-34)	20-40	112-140 (30-34)	23 (17)	130-180
Ni-Resist D-5B	370-450 (53-64)	210-290 (30-41)	7-10	112-123 (16-18)	8 (6)	140-190
Ni-Resist D-5S	370-500 (53-71)	200-290 (29-41)	10-20	110-145 (16-21)	-	130-170
Ni-Resist D-6	390-470 (56-67)	210-260 (30-37)	15-18	140-150 (20-21)	-	120-150

Thermal expansion

For the various Ni-Resist alloys, the coefficients of thermal expansion range from 5.0 to 18.7 $\mu\text{m}/\text{m}/^\circ\text{C}$ (2.8 to 10.4 $\mu\text{in}/\text{in}/^\circ\text{F}$). These values for a given alloy can vary with the nickel content within the specified composition. Thus, by

selecting the Ni-Resist alloy and the nickel content a thermal expansion rate that matches that of many other materials can be found. *Table 9* lists the coefficients of thermal expansion for D-5S.

Table 7 Typical physical properties of flake graphite Ni-Resist alloys

Common name	Density g/cm^3 (lb/in^3)	Thermal expansion* $\mu\text{m}/\text{m}/^\circ\text{C}$ ($\mu\text{in}/\text{in}/^\circ\text{F}$)	Thermal conductivity $\text{W}/\text{m}\cdot\text{K}$ ($\text{BTU}/\text{ft}\cdot\text{hr}\cdot^\circ\text{F}$)	Specific heat $\text{J}/\text{kg}\cdot\text{K}$	Electrical resistivity $\mu\Omega\cdot\text{m}$	Magnetic permeability
NiMn 13 7	7.4 (0.268)	17.7 (9.8)	38-42 (22-24.3)	-	1.2	1.02
Ni-Resist 1	7.3 (0.264)	18.7 (10.4)	38-42 (22-24.3)	460-500	1.6	1.03
Ni-Resist 1b	7.3 (0.264)	18.7 (10.4)	38-42 (22-24.3)	460-500	1.1	1.05
Ni-Resist 2	7.3 (0.264)	18.7 (10.4)	38-42 (22-24.3)	460-500	1.4	1.04
Ni-Resist 2b	7.4 (0.268)	18.7 (10.4)	38-42 (22-24.3)	460-500	1.2	1.04
Nicrosilal	7.4 (0.268)	18.0 (10.0)	38-42 (22-24.3)	-	1.6	1.10
Ni-Resist 3	7.4 (0.268)	12.4 (6.9)	38-42 (22-24.3)	460-500	-	magnetic
Ni-Resist 4	7.4 (0.268)	14.6 (8.1)	38-42 (22-24.3)	460-500	1.6	2.00
Ni-Resist 5	7.6 (0.275)	5.0 (2.8)	38-42 (22-24.3)	460-500	-	magnetic
Ni-Resist 6	7.3 (0.264)	18.7 (10.4)	38-42 (22-24.3)	-	-	-

* 20-200 °C (70-400 °F)

Table 8 Typical physical properties of spheroidal graphite Ni-Resist alloys

Common name	Density g/cm^3 (lb/in^3)	Thermal expansion* $\mu\text{m}/\text{m}/^\circ\text{C}$ ($\mu\text{in}/\text{in}/^\circ\text{F}$)	Thermal conductivity $\text{W}/\text{m}\cdot\text{K}$ ($\text{BTU}/\text{ft}\cdot\text{hr}\cdot^\circ\text{F}$)	Electrical resistivity $\mu\Omega\cdot\text{m}$	Magnetic permeability	Modulus of elasticity GPa
Ni-Resist D-2	7.4 (0.268)	18.7 (10.4)	12.6 (7.3)	1.0	1.02	112-133
Ni-Resist D-2W	7.4 (0.268)	18.7 (10.4)	12.6 (7.3)	-	1.04	112-133
Ni-Resist D-2B	7.45 (0.270)	18.7 (10.4)	12.6 (7.3)	1.0	1.05	112-133
Nicrosilal Spheronic	7.35 (0.266)	18.0 (10.0)	12.6 (7.3)	-	-	-
Ni-Resist D-2C	7.4 (0.268)	18.4 (10.2)	12.6 (7.3)	1.0	1.02	85-112
Ni-Resist D-2M	7.45 (0.270)	14.7 (8.2)	12.6 (7.3)	-	1.02	120-140
Ni-Resist D-3A	7.45 (0.270)	12.6 (7.0)	12.6 (7.3)	-	magnetic	112-130
Ni-Resist D-3	7.45 (0.270)	12.6 (7.0)	12.6 (7.3)	-	magnetic	92-105
Ni-Resist D-4A	7.45 (0.270)	15.1 (8.4)	12.6 (7.3)	-	magnetic	-
Ni-Resist D-4	7.45 (0.270)	14.4 (8.0)	12.6 (7.3)	1.0	1.10	-
Ni-Resist D-5	7.6 (0.275)	5.0 (2.8)	12.6 (7.3)	-	magnetic	112-140
Ni-Resist D-5B	7.7 (0.279)	5.0 (2.8)	12.6 (7.3)	-	magnetic	112-123
Ni-Resist D-5S	7.45 (0.270)	12.9 (7.2)	12.6 (7.3)	-	magnetic	110-145
Ni-Resist D-6	7.3 (0.264)	18.2 (10.1)	12.6 (7.3)	1.0	1.02	-

* 20-200 °C (70-400 °F)

Thermal conductivity

The thermal conductivities of the Ni-Resist alloys are very consistent within a class, either flake or spheroidal graphite. This is easily seen in *Tables 7 and 8*. It is also obvious that the thermal conductivity of the flake graphite alloys is considerably higher than that of the spheroidal graphite ones; that is, about 40 W/m.K versus 12.6 W/m.K, respectively.

Electrical resistivity

The electrical resistivity of some of the alloys is given in *Tables 7, 8 and 23*. In general, the spheroidal graphite alloys have lower values. If electrical conductivity is an important property, they are usually preferred.

Magnetic properties

The magnetic permeability of the Ni-Resists is strongly influenced by the presence of carbides. Since their number and size can depend on heat treatment and other factors, measurements of magnetic properties are often variable. While Ni-Resists NiMn 13 7 and D-6 are usually considered the only truly non-magnetic alloys, D-2 and, especially, D-2C have been used in many non-magnetic applications. The data in *Tables 7 and 8* are compiled from the specifications in Part II. The magnetic permeabilities of some Ni-Resists and other alloys are shown in *Table 24*.

Table 9 D-5S Ni-Resist linear thermal expansion					
Temperature range		Mean coefficient of linear thermal expansion (10 ⁻⁶)			
(Room temperature to indicated T)		As cast		Annealed*	
°C	°F	/°C	/°F	/°C	/°F
93	200	10.8	6.0	9.5	5.3
204	400	13.3	7.4	12.6	7.0
316	600	14.5	8.0	13.9	7.7
427	800	15.2	8.4	14.7	8.2
530	1000	15.9	8.8	15.3	8.5
649	1200	16.4	9.1	15.8	8.8
760	1400	16.7	9.3	16.0	8.9
871	1600	17.1	9.5	16.4	9.1

* 954 °C (1750 °F) / 2 hours / Air cooled

PROPERTIES AFFECTING DESIGN AND MANUFACTURE

Design of castings

Pattern design and shrinkage allowance are similar for flake and spheroidal graphite Ni-Resist alloys of similar nickel content. The shrinkage allowance decreases with increasing nickel content. For the lower nickel grades (Ni-Resists 1,1b, 2, 2b and the various D-2s) it is 0.02 mm/mm (0.25 in/ft). At intermediate levels of nickel (Ni-Resists 3, 4, D-3 and D-4) it is 0.015 mm/mm (0.19 in/ft) and at the highest nickel contents (Ni-Resists 5 and the D-5s) it is 0.01 mm/mm (0.125 in/ft). The same precautions taken for the design of high strength grey iron castings apply to all Ni-Resist alloys. The principle of "controlled directional solidification" should be followed. This means that a casting should be designed to freeze without interruption from light to heavy sections. Abrupt changes in section thickness should be avoided. Provision should be made for the proper placement of feeders. It is always helpful if foundry engineers are consulted during casting design.

Machining

The machinability of Ni-Resist alloys is inferior to that of pearlitic grey cast iron but usually better than cast steels. The chromium content is the most important factor in determining the machinability of the various grades of Ni-Resist alloys. As chromium content increases machinability is reduced because of increasing amounts of hard carbides. Of course, good machining practices should always be followed. Proper selection of cutting tools, cutting lubricants and speed and feed rates are necessary for optimum results.

HEAT TREATMENT

Stress relief

It is advantageous to use heat treatment to stress-relieve Ni-Resist castings to remove residual stresses formed during cooling after casting and subsequent machining. This is done by heating to 600-650 °C (1110-1200 °F) at a rate of 50-100 °C/hour (90-180 °F/hour). The castings should be held in this temperature range for 2 hours plus 1 hour per 25mm (1 inch) of section thickness. They should then be furnace-cooled to or near ambient temperature. With castings made from Ni-Resist alloys with the higher coefficients of expansion and with thin sections, it is most important to have controlled, uniform heating and slow cooling. A small reduction in yield strength may occur after stress relieving.

High temperature stability

Ni-Resist castings intended for static or cyclic service at 480 °C (900 °F) and above can be given a dimensional stabilisation heat treatment. If not done, carbon is slowly removed from the austenite matrix while at service temperatures. This results in a small growth in volume and distortion can occur. When the heat treatment is used this problem is eliminated. The proper cycle is to heat to 850-900 °C (1560-1650 °F) at 50-100 °C (90-180 °F) per hour. The castings should be held in this temperature range for not less than 2 hours plus 1 hour for each 25mm (1 inch) of section thickness followed by air cooling.

Normalising

The same heat treatment that is used for high-temperature stabilisation can be used for normalising. It will result in an increase in yield strength and elongation.

Annealing

If Ni-Resist castings of the correct composition are higher in hardness than expected, excessive carbide formation has probably occurred. Some softening and improved machinability can be achieved through high-temperature annealing. This heat treatment will breakdown and/or spheroidise some of the carbides. To anneal, castings should be heated to 950-1025 °C (1740-1875 °F) at 50-100 °C (90-180 °F) per hour. They should be held in this temperature range for 2 hours per 25 mm (1 inch) of section thickness followed by cooling in the furnace or in still air.

Ambient temperature stability

For assured dimensional stability for service at ambient temperatures, slow, uniform heating to 815-840 °C (1500-1560 °F) is suggested. Castings should be held in this temperature range for one hour per 25 mm (1 inch) of section thickness and uniformly cooled to at least 315 °C (600 °F). For stringent requirements, the uniform cooling can be continued to ambient temperature.

WELDING

Ni-Resist alloys are all capable of being welded, provided that correct welding parameters are followed, and that sulphur and phosphorus contents are controlled to proper limits. The degree of welding that is possible varies from alloy to alloy as described

in the following. In general, the flake graphite Ni-Resists are slightly tougher and more ductile than grey cast irons and, despite their higher coefficients of expansion, have proved to be tolerant to welding stresses. Where welding will be required and to prevent hot cracking in the weld heat affected zone, sulphur and phosphorus must be controlled to 0.04% or less. The superior mechanical properties, toughness and ductility of spheroidal graphite Ni-Resists suggest enhanced weldability over ordinary grey cast iron and flake graphite Ni-Resist alloys. In practice, this is not necessarily correct. The presence of the magnesium required for the spheroidisation process decreases ductility at the welding temperature and small cracks can occur in the weld heat affected zone. Because of this problem, alloy D-2W was developed. In this material, the addition of niobium (columbium), combined with the control of silicon, phosphorus and the residual magnesium contents, has led to an alloy with very adequate weldability. Practical experience has demonstrated excellent welding reparability of major casting defects.

Welding practice

Most welding will be concerned with the repair or reclamation of castings, but in any case, preparations prior to welding are always very important. It is recommended that all unsound metal be removed before starting by machining, chipping or grinding. If the former two methods are used, only carbide tipped tools should be employed. To ensure that only sound metal remains, a dye penetrant should be employed. The actual area to be welded should be wider and more open than for steel. This is shown in *Figure 3*. Since positional welding is difficult with certain electrodes, the work piece should be placed for downhand welding. A thin weld coating

Figure 3 Examples of preparation and welding procedures for repairs to defects in castings

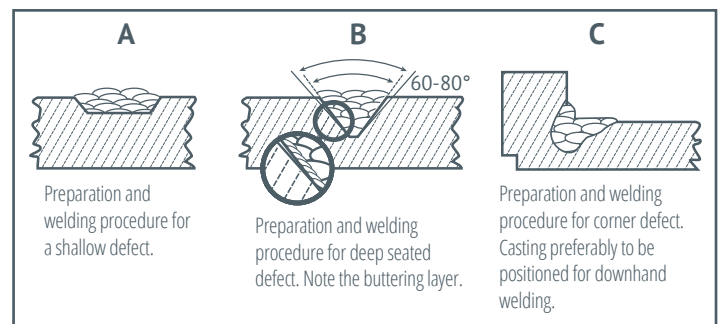

or “buttering” of the surface, prior to welding greatly assists in preventing heat affected zone cracking.

The usual welding process is shielded metal arc with flux coated electrodes. The choice of electrodes is critical with the widely available 55% nickel/iron types strongly suggested. This composition is used for welding ordinary grey cast iron and is suitable for flake graphite Ni-Resist alloys. Most 55% nickel/iron electrodes deposit metal with a tensile strength equal to that of Ni-Resist alloys D-2, D-2B and D-2W. However, they are often lacking in impact toughness. To avoid this problem, the electrode selected to weld spheroidal graphite alloys should be carefully evaluated to provide a deposit with acceptable soundness, toughness and machinability. Ease of operation and freedom from slag inclusions in the weld metal are also important properties. It is very important to follow the electrode manufacturer’s instructions for storage, drying, baking and using the electrodes.

Following welding, all slag and weld spatter should be thoroughly removed by brushing or grinding. Peening should not be done. Undercuts should be removed by grinding and carefully refilled.

Welding heat treatments

When welding flake graphite Ni-Resist alloys, preheating to 300-350 °C (570-660 °F) is recommended. The interpass temperature should also be maintained at that level. On completion of welding, care should be taken to allow slow cooling in still air. For complex welds, transfer to a preheated oven or furnace and slow cooling under controlled conditions may be advantageous.

Preheating is normally unnecessary when welding spheroidal graphite alloys. However, in practice, it is sometimes beneficial to use a low preheat to about 100 °C (212 °F) when welding conditions are not ideal and cold air drafts are present. A low maximum interpass temperature of 150 °C (300 °F) is essential for the ductile Ni-Resists.

Post weld heat treatments are usually not necessary for structure or properties in any Ni-Resist alloy. Post-weld stress relief, however, is often required, especially if castings are to be exposed to an environment where stress corrosion cracking is a possibility. The heat treatment procedures for stress relief given previously should be followed.

Effect of chemical composition on welding

It was mentioned above that the addition of niobium (columbium) to the alloy D-2 composition led to the development of the more weldable grade, D-2W. In utilising this alloy, attention must be paid not only to the niobium content (0.12% min.), but also to silicon (2.25% max.), phosphorous (0.04% max.) and magnesium (0.05% max.). There also appears to be an inter-relationship between these elements which assists in obtaining excellent toughness and ductility, without any significant changes in other mechanical properties. In addition to type D-2W, a niobium addition seems to have a beneficial effect on other Ni-Resist alloys, although the research in this area has been limited. Research has also indicated that a higher level of chromium content can improve welding response. Thus, alloys such as D-2B have satisfactory weldability. This is despite the lower ductility and higher propensity to micro-porosity caused by increased chromium. A niobium addition and control of the other elements as in alloy D-2W is also advantageous with this type of composition.

PROPERTIES AFFECTING SERVICE PERFORMANCE WEAR AND GALLING RESISTANCE

The presence of dispersed graphite, as well as the work hardening characteristics of Ni-Resist alloys, bring about a high level of resistance to frictional wear and galling. Ni-Resists 2, D-2, D-2C, D-3A, 4 and D-4 offer good wear properties with a wide variety of other metals from sub-zero to elevated temperatures. In the case of the ductile alloys, temperatures can go as high as 800 °C (1500 °F). Ni-Resists D-2B, 3 and D-3 are not recommended for frictional wear applications because their microstructures contain massive, hard carbides that can abrade the mating metal.

When comparing Ni-Resist alloys to other metals, Ni-Resists D-2 and D-2C have been shown to have the lowest frictional wear rates when compared to bronze, regular ductile iron and nickel/chromium alloy N06600. Between the two Ni-Resist alloys, D-2 had the least wear.

With mating parts, it is often useful to “wear-in” the two surfaces. During this operation prior to actual service, a solid lubricant such as molybdenum disulphide is effective. A work-hardened, glazed surface develops which resists wear and extends life.

CORROSION RESISTANCE

It is usually said that Ni-Resist alloys have a corrosion resistance intermediate between grey and low alloy cast irons and stainless steel. This statement is an over-simplification of their usual form of corrosion. They corrode in a manner similar to the grey cast irons, but because of their chemical composition, form denser, more adherent corrosion product films which suppress further corrosion. They are not stainless steels and do not behave as they do. In neutral and mildly acidic halide-containing solutions, stainless steels often corrode in destructive localised ways. That is, they suffer pitting, crevice corrosion and, sometimes, stress corrosion cracking. Ni-Resist alloys seldom have these forms of attack. Their corrosion is usually uniform at low rates. Of course, Ni-Resists do not have the typically good corrosion resistance of stainless steel in mild and/or strongly oxidising acids and should not be used in such environments.

In addition to the comments, tables and figures in this section of this brochure, the corrosion behaviour of Ni-Resist alloys in many different environments is given in Part III. Please refer there for specific media and service conditions.

Special forms of attack

Galvanic corrosion: Galvanic corrosion occurs when two substances with different electrochemical potentials (activities) are in contact in a conducting solution or electrolyte. In *Figure 4*, the relative potential of Ni-Resist alloys to other metals and alloys is given in moderate velocity, ambient temperature seawater. The Ni-Resists are less active (cathodic) than zinc, aluminium alloys, low alloy steels and cast iron. This means that the corrosion rate of these alloys will be accelerated when they are in contact with Ni-Resists. *Figure 4* also shows that Ni-Resist alloys are active (anodic) with regard to copper-base alloys, stainless steels and nickel-base alloys. Thus, they will corrode preferentially to these materials. In order to distribute the corrosion over a large area, designers and engineers should always provide for a larger relative area of Ni-Resist when it is in contact with these types of alloys. When this is done serious problems in the galvanic corrosion of Ni-Resists will usually not occur. Typical examples that are particularly successful are stainless steel trim in Ni-Resist valves and stainless steel impellers and shrouds in Ni-Resist pumps.

Graphitisation: In cast irons, graphite occurs as flakes or spheroids in a metal matrix. Certain environments, such as seawater, other salt solutions and soil, cause the metal matrix to corrode preferentially, leaving a structure of hydrated iron oxide and graphite particles. This form of attack is called graphitisation or graphitic corrosion. The graphite/oxide surface layer is often porous and, because of the potential difference between graphite and iron, accelerated corrosion of the underlying cast iron can occur. Other iron, steel or bronze parts are also active with respect to graphitised cast iron and corrode at high rates. Because of their inherently superior corrosion resistance, Ni-Resist alloys are less apt to form a graphitised surface layer. Thus, the above problems are largely avoided. When Ni-Resists do form a graphitised layer, the acceleration of their corrosion is much less because the potential difference between Ni-Resist alloys and graphite is smaller than with cast iron.

Erosion-corrosion: Although not as good as austenitic stainless steels, the Ni-Resist alloys, when compared to most cast irons and steel, have excellent ability to resist the combined effects of corrosion and erosion in high velocity

Figure 4 Galvanic series of various metals in flowing seawater at ambient temperatures. Velocity range: 2.4-4.0 metre/sec (8-13 feet/sec), temperature range: 10-27°C(50-80°F)

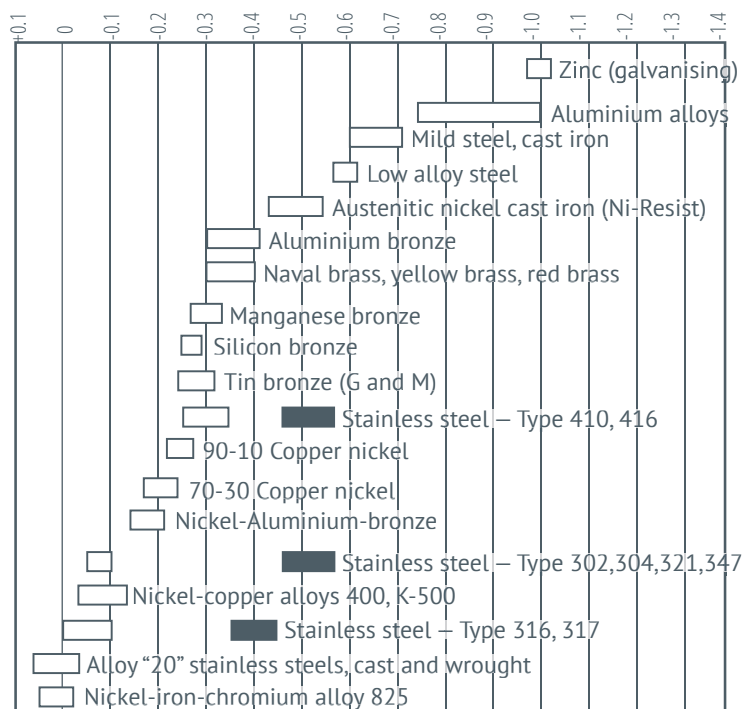

solutions. When ordinary and low-alloy cast irons corrode in aqueous environments, a loosely adherent corrosion product layer of hydrated iron oxides and graphite is formed. If velocities exceed 3.0-3.7 m/sec (10-12 ft/sec), this film is washed away, continuously exposing fresh metal surfaces for ongoing corrosion. The Ni-Resists, particularly those that contain chromium, form denser, more adherent corrosion product surfaces. Because of this, they can resist high fluid flow velocities. For example, see *Tables 10* and *11*. When solids are present it is desirable to select the harder types of Ni-Resist, such as 2b, D-2B, 4 and D-4.

Cavitation damage: Cavitation damage is the mechanical fracturing of a metal surface in fluids under conditions

Table 10 Corrosion of cast materials in low velocity seawater	
Duration of test:	3 years
Temperature:	Ambient
Agitation:	Tidal flow with continuous immersion
Marine fouling:	All specimens completely covered with fouling organisms at time of removal from test
Material	Corrosion rate mm/y (mpy)
Ni-Resist 1	0.053 (2.1)
Ni-Resist 2	0.043 (1.7)
Ni-Resist D-2	0.041 (1.6)
Ni-Resist 3	0.038 (1.5)
Ductile grey cast iron	0.246 (9.7)
Grey cast iron	0.254 (10)

Table 11 Corrosion of pump materials in high velocity seawater			
Alloy	Temperature °C (°F)	Velocity m/sec (ft/sec)	Corrosion rate* mm/y (mpy)
Type 316 Stainless steel	10 (50)	43 (141)	0.005 (0.2)
Ni/Cu alloy 400	11 (52)	43 (141)	0.010 (0.4)
Ni-Resist 1	27 (81)	41 (134)	0.990 (40)
88Cu/10Sn/2Zn	2 (36)	42 (138)	1.10 (44)
85Cu/5Sn/15Zn/5Pb	25 (77)	41 (134)	1.35 (54)
Grey cast iron	20 (68)	38 (125)	13.5 (540)

* All tests were 30 days duration except for Grey Cast Iron. Because of excessive attack on specimens of this material its tests were stopped after 10 days.

which cause large cyclic hydraulic pressure changes. For example, as a pump impeller rotates at high velocity, it produces alternating areas of high and low pressure on the casing wall. During the low-pressure cycle, bubbles can form in the liquid. They subsequently collapse under high pressure and the fluid “hammers” the metal surface. The alternating character of the stresses induce a condition which leads to metal fatigue. Metals that are stronger, harder and have higher corrosion fatigue strength resist cavitation damage best. Thus, the Ni-Resists are superior to most other cast irons with alloys 1b, 2b, D-2B, 4 and D-4 being preferred.

Stress corrosion cracking: Stress corrosion cracking is the brittle failure of metals when exposed to specific media. The stresses involved can be well below the elastic limit and are almost always residual rather than applied. Common examples are austenitic stainless steels in hot chloride-containing solutions, carbon and low alloy steels in strong caustics and copper alloys in ammoniacal environments. Ni-Resist alloys are highly resistant to this form of corrosion, but there have been some probable stress corrosion cracking failures in warm seawater. The problem is greatly alleviated and probably eliminated by proper stress relief heat treatment after casting, welding, and machining. The procedures for this are given on page 13. Other work has suggested that the ductile grades of Ni-Resist are more resistant to stress corrosion cracking than the flake graphite alloys or that some ductile grades are better than others in this regard. These are not absolute solutions to the problem, because the assigning of degrees of susceptibility is of questionable merit. It is best to consider all Ni-Resists to be equal in this regard. Additionally, when examining Ni-Resist alloys after cracking failures, the possibility of poor-quality castings, corrosion fatigue and other failure modes should be considered before deciding on an inherent susceptibility to stress corrosion cracking.

Corrosion fatigue: Metallic fatigue failures can occur when a metal is subject to many cyclic stresses below the elastic limit. In air, most metals have a fatigue limit or stress below which fatigue failures do not occur. However, in a corrosive media this fatigue limit is lowered and does not exist for continuously corroding metals. Because of their better

corrosion resistance in aqueous solutions than ordinary cast irons, Ni-Resist alloys might be expected to have better corrosion fatigue resistance than ordinary cast irons. However, this has not been observed, possibly because the corrosion product film is continually being fractured by the cyclic stresses and its protectiveness is not permitted to develop.

Atmospheric corrosion: The Ni-Resist alloys are similar in performance to the “weathering” steels in that they form dense, self-protecting corrosion product surfaces during exposure to air. There are substantial advantages over unalloyed cast iron and steel. Painting and other protective coatings are usually not required.

Figure 5 Corrosion behaviour of cast irons and copper-containing steel in a marine atmosphere 240 metres (800 feet) from the sea – North Carolina, USA

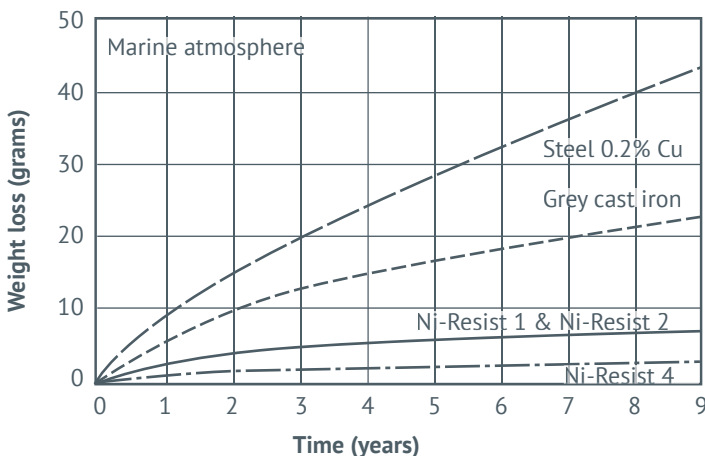
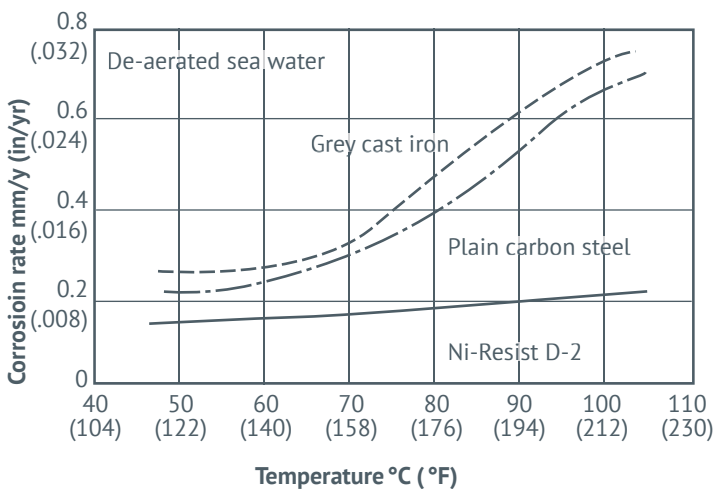

Figure 6 Corrosion in de-aerated seawater as a function of temperature



Corrosion performance in specific environments

Marine environments: Ni-Resist alloys are very well suited for several important applications near and in seawater. *Figure 5* illustrates this superiority from long term tests in a marine atmosphere 240 metres from the sea. When immersed in seawater the Ni-Resists provide advantages over other metals at velocities ranging from no flow to turbulent conditions. This is shown in *Tables 10, 11* and *12*. *Figures 6* and *7* demonstrate the good performance of Ni-Resist D-2 in aerated and de-aerated seawater with increasing temperature. The high velocity performance, including resistance to erosion-corrosion and cavitation damage, is the primary reason Ni-Resist alloys are so frequently selected for use in seawater pumps and valves. Ni-Resists D-2 and D-2W are commonly preferred.

Petroleum production: Ni-Resist alloys find major applications in oil and gas production. In crude or “sour” oil and gas containing hydrogen sulphide, carbon dioxide and organic acids, self-protective corrosion deposits result in low corrosion rates. This is shown in *Tables 13* and *14*. The hard, carbides in the chromium containing grades of Ni-Resist impart erosion resistance and are useful when sand and other solids are present. The combination of seawater and petroleum fluids corrosion resistance makes Ni-Resist alloys well suited for applications in offshore oil and gas production. Because of their lower chromium content, Types D-2C, D-2M,

Figure 7 Corrosion in aerated seawater as a function of temperature

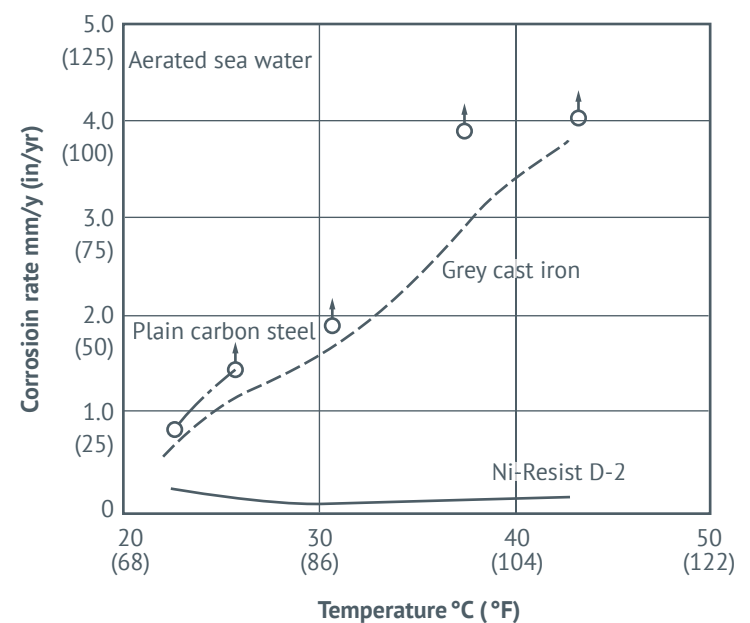

D-3A and D-5 would be expected to have somewhat reduced corrosion performance.

Alkaline environments: Ni-Resist austenitic cast irons are widely used in handling sodium hydroxide and other strong caustics. The addition of nickel to iron results in a marked improvement in corrosion resistance in such environments. This is clearly shown in *Tables 15* and *16*. Because of their high (30%) nickel content, Ni-Resists 3, D-3 and D-3A are preferred. Iron-base alloys often suffer stress corrosion

Table 12 Erosion-corrosion of various alloys in high velocity seawater	
Duration:	60 days
Temperature:	23-28 °C (73-82 °F)
Velocity:	8.25 m/s (27 ft/sec)
Condition:	Turbulent flow
Material	Corrosion rate mm/y (mpy)
Grey cast iron	6.86 (270)
2% Nickel cast iron	6.10 (240)
88/10/2 Cu/Sn/Zn Bronze	1.17 (46)
65/35 Cu/Zn Brass	1.07 (42)
Aluminium bronze	0.92 (36)
Ni-Resist 2	0.79 (31)
90/10 CuNi	0.51 (20)
5 % Nickel Aluminium bronze	0.30 (12)
Ni-Resist 1	0.20 (8)
Ni-Resist 3	0.18 (7)
NiCu Alloy K500	0.08 (3)
25/20 CrNi Stainless steel	0.05 (2)

Table 13 Weight loss in still natural gas with hydrogen sulphide at 80 °C (180 °F)				
	100 hours	200 hours	300 hours	400 hours
Alloy	g/m ² (lb/ft ²)			
Ni-Resist 1	60 (0.007)	83 (0.010)	83 (0.010)	83 (0.010)
Grey cast iron	79 (0.010)	189 (0.023)	222 (0.027)	248 (0.030)
Piston ring grey cast iron	157 (0.019)	215 (0.026)	253 (0.031)	295 (0.036)
Plain carbon steel (0.4% Carbon)	85 (0.010)	218 (0.027)	310 (0.038)	363 (0.044)

cracking failures in hot, strong caustics. This has not been a problem with the Ni-Resists, but a reasonable precaution is to stress relieve all castings prior to being placed in service.

Acid environments: Ni-Resist alloys can be used in dilute and concentrated sulphuric acid at ambient temperature.

Table 14 Corrosion tests in sour crude oils			
Material	Corrosion rate mm/y (mpy)		
	Test 1	Test 2	Test 3
Ni-Resist 1	0.017 (0.7)	0.25 (10)	0.023 (0.9)
Ni-Resist 3	-	0.17 (7)	-
Grey cast iron	0.053 (2.1)	1.13 (45)	0.40 (16)
Mild steel	0.043 (1.7)	1.30 (52)	Consumed
Type 304 Stainless steel	<0.003 (<0.1) *	0.20 (8) **	<0.003 (<0.1)
<i>Tests indicated with an asterisk indicate the maximum depth of pitting observed</i>			
* 0.10 mm (4 mils) pitting			
** 0.30 mm (12 mils) pitting			
Test 1 Exposed in 200,000 litres (55,000 US gallons) sour crude oil storage tank at ambient temperature. Immersed in liquid for 23 days and suspended in vapour above liquid for 52 days.			
Test 2 Exposed in top of crude flash tower at 105-115 °C (220-240 °F) for 43 days. Crude contained 0.34% sulphur, 0.021% sodium chloride.			
Test 3 Exposed in crude oil preheater (average temperature 145 °C (295 °F) with flow rate of 2.10 m/sec (7 ft/sec) for 463 days. Crude contained 0.4% sulphur, 0.031% sodium chloride.			

Table 15 Effect of nickel content on the corrosion rate of cast iron in 50% to 65% sodium hydroxide	
Temperature:	Boiling with vacuum of 66 cm (26 in) of mercury
Duration of test:	81 days
Agitation:	Boiling action only
% Nickel	Corrosion Rate mm/y (mpy)
0	2.12 (83)
3.5	1.19 (47)
5	1.24 (49)
15	0.76 (30)
20	0.084 (3.3)
20 + (2% Cr)	0.152 (6.0)
30	0.010 (0.4)

Intermediate concentrations and higher temperatures are to be avoided. The copper-containing alloys, Ni-Resist 1 and 1b are preferred. They are much better than grey cast iron. In hydrochloric acid, the higher nickel Ni-Resists

such as 3, D-3 and D-3A are marginally useful in dilute solutions at low temperatures. Increases in solution velocity, agitation and aeration adversely affect the corrosion performance of Ni-Resist alloys in most acids throughout temperature and concentration ranges. Data for several acid environments is given in Part III.

Table 16 Plant corrosion tests of various alloys in 74% sodium hydroxide

Duration:	Specimens exposed for 20 days in liquid and 12 days in vapour over liquid. Corrosion rates based on 20 days exposure to liquid.
Temperature:	125 °C (260 °F)
Agitation:	Stagnant (in storage tank)
Material:	Corrosion rate mm/y (mpy)
NiCu alloy 400	0.023 (0.9)
Ni-Resist 3	0.064 (2.5)
Ni-Resist D-2	0.127 (5)
Ni-Resist 2	0.152 (6)
Type 304	0.381 (15)
Mild steel	1.9 (75)
Grey cast iron	1.93 (76)

ELEVATED TEMPERATURE PERFORMANCE

Ni-Resist alloys, when compared to grey and low alloy cast irons, have superior properties at elevated temperatures. This applies to both flake and spheroidal graphite alloys. However, because of much higher mechanical properties and resistance to internal oxidation, the ductile Ni-Resists are preferred at elevated temperatures up to 1050 °C (1930 °F).

Mechanical properties

The high temperature mechanical properties of the spheroidal graphite Ni-Resist alloys are given in *Table 17*. Room temperature properties after 10,000 hours of exposure at various elevated temperatures are shown in *Table 18*. *Figure 8* illustrates the short-term, high temperature tensile properties of Ni-Resist D-2. Creep data for some ductile Ni-Resists are shown graphically in *Figure 9*, along with

Table 17 Typical elevated temperature mechanical properties of some spheroidal graphite Ni-Resist alloys

Property and temperature	D-2	D-2C	D-3	D-4	D-5B	D-5S
Tensile strength	MPa (ksi)					
Ambient	407 (59)	428 (62)	400 (58)	442 (64)	421 (61)	462 (67)
426 °C (800 °F)	373 (54)	359 (52)	-	-	-	-
538 °C (1000 °F)	331 (48)	290 (42)	331 (48)	421 (61)	324 (47)	-
649 °C (1200 °F)	248 (36)	193 (28)	290 (42)	331 (48)	283 (41)	290 (42)
760 °C (1400 °F)	152 (22)	117 (17)	186 (27)	152 (22)	173 (25)	124 (18)
0.2% Yield strength	MPa (ksi)					
Ambient	242 (35)	235 (34)	269 (39)	304 (44)	283 (41)	248 (36)
426 °C (800 °F)	193 (28)	179 (26)	-	-	-	-
538 °C (1000 °F)	193 (28)	159 (23)	193 (28)	283 (41)	179 (26)	-
649 °C (1200 °F)	173 (25)	166 (24)	186 (27)	235 (34)	166 (24)	172 (25)
760 °C (1400 °F)	117 (17)	117 (17)	104 (15)	131 (19)	131 (19)	90 (13)
Elongation from short time tensile tests %						
Ambient	10.5	25	7.5	3.5	7	20.5
426 °C (800 °F)	12	23	-	-	-	-
538 °C (1000 °F)	10.5	19	7.5	4.0	9	-
649 °C (1200 °F)	10.5	10	7.0	11	6.5	20.0
760 °C (1400 °F)	15	13	18	30	24.5	44.0

Figure 8 Short time tensile properties of Ni-Resist D-2 at elevated temperatures

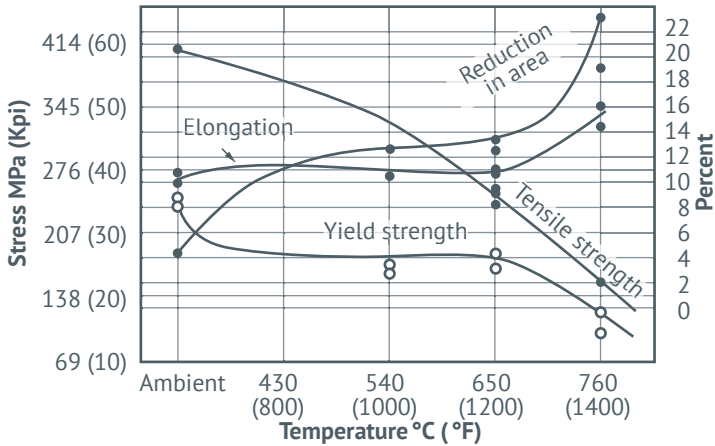

Figure 9 Creep behaviour of several spheroidal graphite Ni-Resist alloys and CF-4 stainless

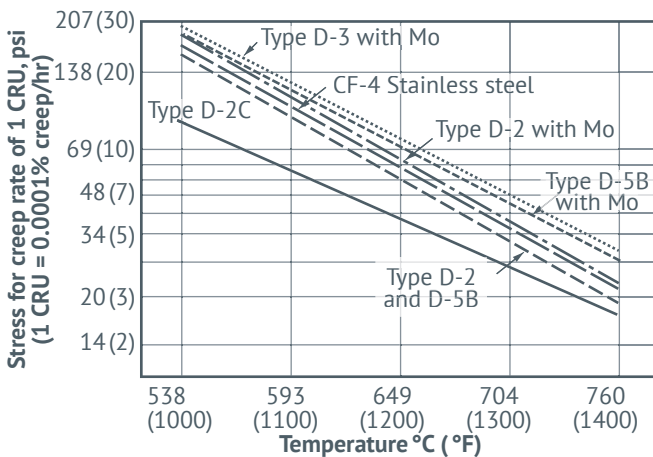

Figure 10 Stress rupture data for Ni-Resist D-2

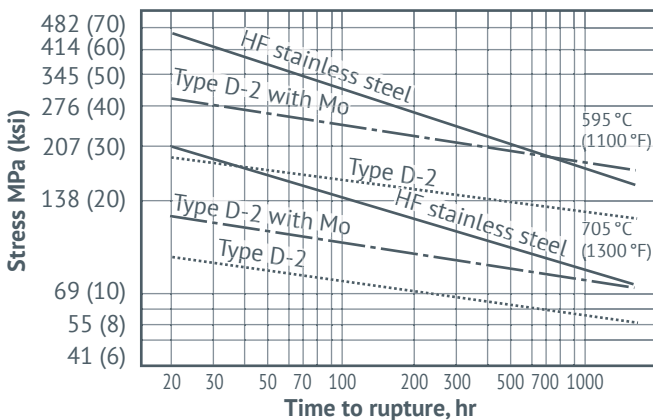

Figure 11 Stress rupture data for Ni-Resist D-3

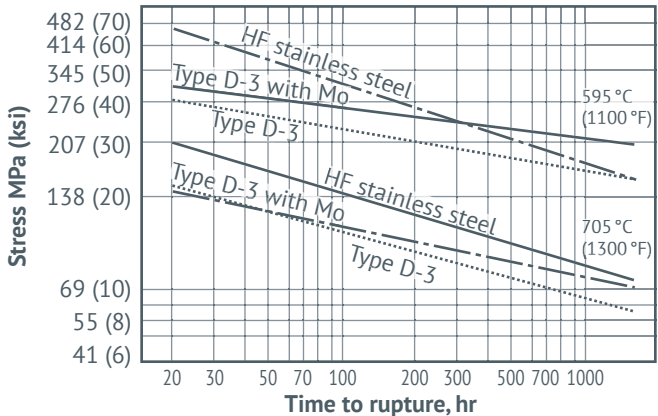

Figure 12 Stress rupture data for Ni-Resist D-5B

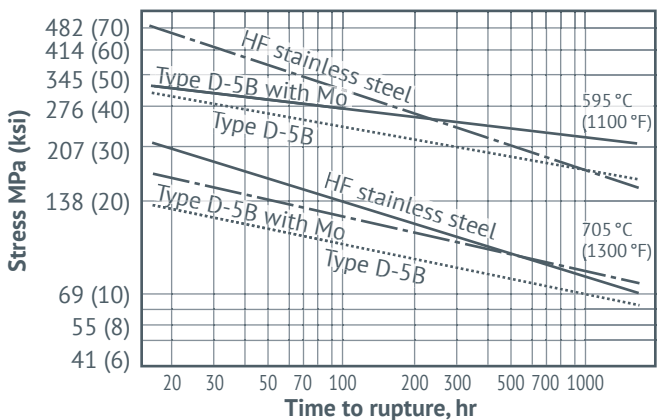
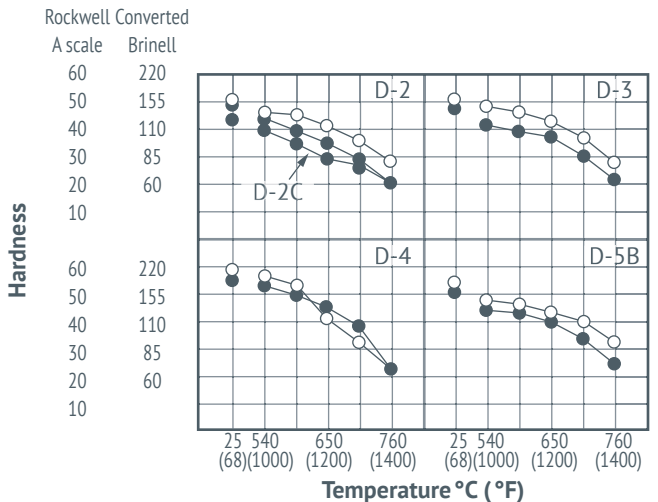

Figure 13 Hot hardness of some spheroidal graphite Ni-Resist alloys. Solid symbols are standard compositions. Open symbols are alloys with 0.7%-1.0% Mo added



a comparison to CF-4 cast stainless steel (18Cr, 8Ni). The stress rupture curves for Ni-Resists D-2, D-3 and D-5B, with and without molybdenum, are given in *Figures 10, 11 and 12* along with the data for HF cast stainless steel (19Cr-9Ni). The hot hardness values of Ni-Resists D-2, D-3, D-4, and D-5B, also with and without molybdenum, are shown in *Figure 13*, although a variation from the specification, it is important to note that the addition of 0.5-1.0% molybdenum to ductile Ni-Resists usually raises the elevated temperature mechanical properties with only a slight reduction in elongation. Plus, molybdenum improves the stress rupture and creep performance, as shown in *Figures 9, 10, 11 and 12*, such that the resultant alloys are equal to or superior to HF and CF-4. The addition of molybdenum also raises the as-cast hardness, except for Ni-Resist D-4, and maintains it at elevated temperatures (see *Figure 13*).

Resistance to cracking and distortion

During cyclic heating and cooling to temperatures of 675 °C (1250 °F) and above, cast iron and steels pass through a critical range which frequently results in cracking and/or distortion of castings. Volume changes which lead to this problem occur because of matrix phase changes between ferrite and austenite at this temperature. The Ni-Resists, being austenitic at all temperatures do not have a transformation and have no sharp volume changes. However, there can be the slight high temperature stability problem described in the heat treatment section. Using the suggested heat treatment will alleviate any troubles.

Steam service

Ni-Resist alloys D-2 and D-3 have been excellent for applications requiring resistance to wet steam erosion. At higher steam temperatures, where resistance to growth and scaling is important, these same materials are also superior. Steam turbine components such as diaphragms, shaft and labyrinth seals and control valves are examples of applications. *Table 17* and *Figure 8* give useful elevated temperature mechanical properties for steam service. *Table 19* favourably compares the growth of some Ni-Resist alloys to grey cast iron in steam at 482 °C (900 °F).

Resistance to elevated temperature oxidation

Both flake and spheroidal graphite Ni-Resists have high temperature oxidation performance up to ten times better than that for grey cast iron. The high chromium and high silicon grades, especially, form dense, adherent self-protecting oxide scales. However, because of the preference for the

Table 19 Growth of grey cast iron and some Ni-Resist alloys in steam at 482 °C (900 °F)

Alloy	Growth in cm/cm (in/in)		
	500 hours	1000 hours	2500 hours
Grey cast iron	0.0023	0.0052	0.014
Ni-Resist 2	0.0005	0.0010	0.0015
Ni-Resist 3	0.0003	0.00045	0.00048
Ni-Resist D-2	0.0003	0.0005	0.0005
Ni-Resist D-3	0.0003	0.0000	0.0000

Table 18 Room temperature mechanical properties after 10,000 hours exposure at indicated temperature

Alloy	Temperature	Tensile strength	Yield strength, 0.2%	Elongation	Charpy impact
	°C (°F)	MPa (ksi)	MPa (ksi)	%	J (ft-lbf)
Ni-Resist D-2	550 (1022)	455 (66.0)	278 (40.3)	6.0	7.4 (5.5)
	660 (1202)	497 (72.0)	254 (36.8)	7.5	9.7 (7.2)
Ni-Resist D-2 with 1% Mo	550 (1022)	459 (66.5)	302 (43.7)	3.0	4.8 (3.6)
	660 (1202)	490 (71.0)	300 (43.5)	4.0	4.8 (3.6)
Ni-Resist D-2B	550 (1022)	452 (65.5)	312 (45.2)	4.0	5.4 (4.0)
	660 (1202)	483 (70.0)	274 (39.7)	5.0	6.3 (4.7)
Ni-Resist D-3	600 (1202)	495 (71.7)	268 (38.8)	8.0	9.7 (7.2)
Ni-Resist D-5S*	870 (1600)	513 (74.4)	222 (32.2)	23.0	-

*2500 hours exposure

higher strength ductile alloys for elevated temperature service, only they will be considered here. For example, ductile Ni-Resists D-2, D-2B, D-3, D-4, D-5B and D-5S provide good resistance to oxidation and maintain useful mechanical properties up to 760 °C (1400 °F). At higher temperatures, alloys D-2B, D-3, D-4 and D-5S can be considered with D-5S having good oxidation resistance up to 925 °C (1700 °F). While Type D-5B has shown high strength (slightly above Type D-5S), it does not have as good oxidation resistance as D-5S because of the lower silicon and chromium contents. Type D-5S has often been chosen for such high temperature applications as exhaust manifolds and super-charger housings in diesel engines. The stress-rupture and creep behavior of Ni-Resist D-5S is shown in *Figures 14 and 15*.

Table 20 provides oxidation data for some ductile Ni-Resists and other alloys, under both static and cyclic conditions. Thermal cycling causes the metal to expand and contract regardless of whether any phase changes occur. This leads to cracking and flaking of the protective scale. To minimise this, low expansion grades of Ni-Resist, such as D-4, should be considered. If high toughness is not required, it can be used at least to 815 °C (1500 °F).

The presence of appreciable sulphur-containing gases in a high temperature environment can greatly reduce the useful service life of Ni-Resist and other alloys. Usually the maximum temperature must be lowered by 200-300 °C (360-540 °F).

Table 20 Oxidation of various alloys for different times and temperatures		
Material	Penetration per year mm (in.)	
	Test 1	Test 2
Ductile iron 2.5% Si	1.07 (0.042)	12.7 (0.50)
Ductile iron 5.5% Si	0.11 (0.004)	1.30 (0.051)
Ni-Resist D-2	1.07 (0.042)	4.45 (0.175)
Ni-Resist D-2C	1.78 (0.07)	-
Ni-Resist D-4	0.11 (0.004)	0.0 (0.0)
Ni-Resist 2	2.45 (0.098)	7.62 (0.30)
Type 309	0.0 (0.0)	0.0 (0.0)
Test 1 Furnace atmosphere – air, 4000 hours at 704 °C (1300 °F)		
Test 2 Furnace atmosphere – air, 600 hours at 870-925 °C (1600-1700 °F), 600 hours at 315-925 °C (600-1700 °F), 600 hours at 425-480 °C (800-900 °F)		

LOW TEMPERATURE PERFORMANCE

Ductile Ni-Resist alloys generally retain their usual good impact properties to quite low temperatures. The austenitic structure is stable, and they do not have a ductile/brittle transition temperature. *Table 21* gives Charpy V-notch values for six of the alloys from ambient temperature to -196 °C (-321 °F). Most of the alloys show only slight decreases until temperatures drop below -100 °C (-148 °F). At -196 °C (-321 °F), impact values are noticeably lower for Ni-Resists D-2C, D-3 and D-3A. However, there is no reduction for Ni-Resist D-2M which was especially developed for cryogenic service. Low temperature mechanical and impact properties are shown in *Table 22*. Obviously, it is the alloy of choice at these low

Figure 14 Stress rupture curves for Ni-Resist D-5S at 760 °C (1400 °F) and 870 °C (1600 °F)

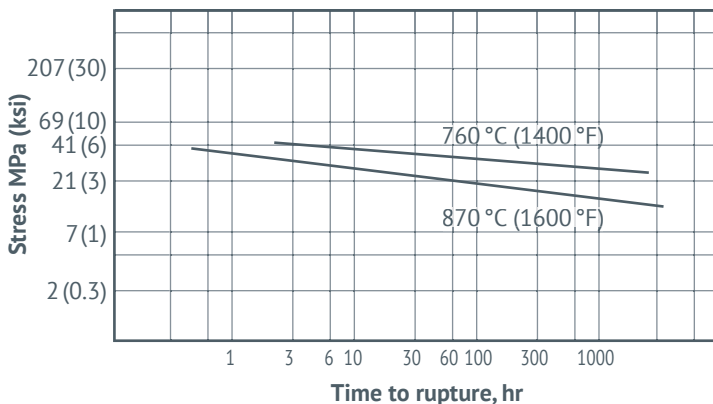
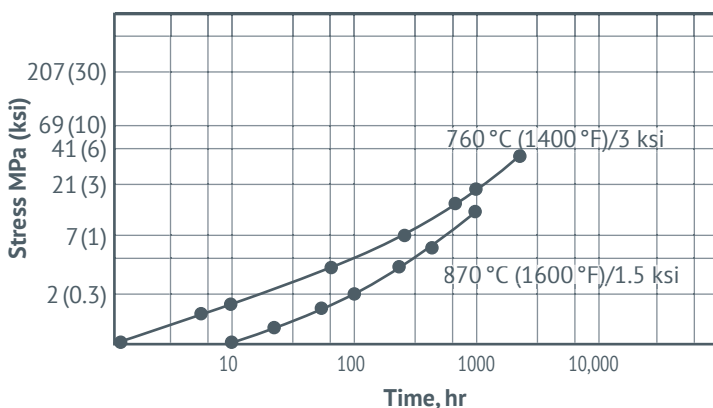

Figure 15 Creep curves for Ni-Resist D-5S at 760 °C (1400 °F)/3 ksi and 870 °C (1600 °F)/1.5 ksi



temperatures. However, it is not an economic or practical substitute for D-2 or D-2W in corrosive environments at ambient and elevated temperatures, regardless of its attractive mechanical properties.

ADVANTAGES AND APPLICATIONS OF THE PHYSICAL PROPERTIES OF NI-RESIST ALLOYS

THERMAL EXPANSION

The Ni-Resist alloys have a wide range of coefficients of thermal expansion. These differences have been exploited in several ways. Average values for the various alloys are given in *Tables 7 and 8*. Reference should be made to Part II for the national and international specifications.

Alloy	Charpy V-Notch J (ft-lbf)				
	20 °C 68 °F	0 °C 32 °F	-50 °C -58 °F	-100 °C -148 °F	-196 °C -320 °F
Ni-Resist D-2	12 (9)	12 (9)	12 (9)	11 (8)	9.5 (7)
Ni-Resist D-2C	32 (24)	32 (24)	38 (28)	35 (26)	13.5 (10)
Ni-Resist D-2M	38 (28)	38 (28)	39 (29)	39 (29)	38 (28)
Ni-Resist D-3	9.5 (7)	9.5 (7)	8.1 (6)	6.7 (5)	4 (3)
Ni-Resist D-3A	-	19 (14)	-	17 (13)	10 (7.5)
Ni-Resist D-5	23 (17)	20 (15)	-	19 (14)	15 (11)

High expansion

The 15% and 20% nickel alloys (Ni-Resists 1, 2, D-2 and their derivatives) are those with relatively high expansion rates. These are the alloys that are often used in conjunction with other metals such as aluminium, copper and austenitic stainless steel which also have high thermal coefficients of expansion. By matching the thermal expansion properties of dissimilar metals, engineers can work to closer tolerances without being concerned about joint warpage. Examples of this practice are Ni-Resist piston ring inserts cast in aluminium pistons, austenitic stainless steel vanes in Ni-Resist pump casings and Ni-Resist heating units in copper heads of soldering irons. Because Ni-Resist D-4 has a similar expansion coefficient to Type 304 (UNS S30400) austenitic stainless steel, stainless steel vanes are used in Ni-Resist turbocharger diaphragms.

Figure 16 Effect of nickel content on the thermal expansion of Ni-Resist D-3

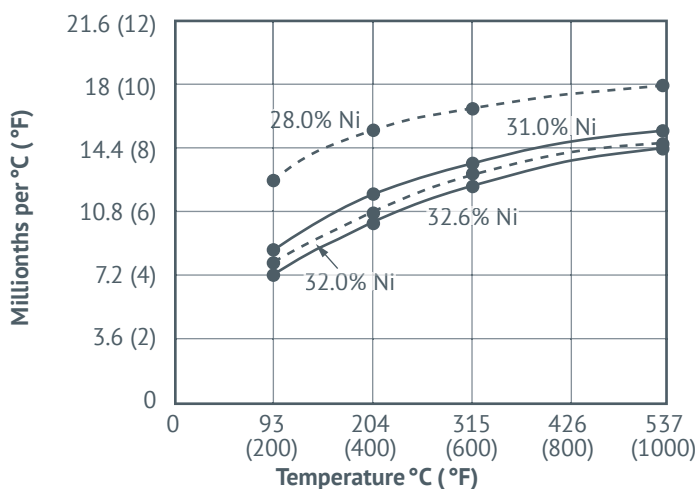

Temp °C (°F)	Tensile strength MPa (ksi)	0.2% Proof stress MPa (ksi)	Elongation %	Reduction of area %	Charpy V-notch J (ft-lbf)
+20 (68)	450 (65)	220 (32)	35	32	39 (29)
0 (32)	450 (65)	240 (34)	35	32	42 (31)
-50 (-58)	460 (66)	260 (37)	38	35	43 (32)
-100 (-148)	490 (71)	300 (43)	40	37	46 (34)
-150 (-238)	530 (76)	350 (50)	38	35	44 (33)
-183 (-297)	580 (84)	430 (62)	33	27	39 (29)
-196 (-320)	620 (90)	450 (65)	27	25	36 (27)

Intermediate expansion

Ni-Resists 3 and D-3 are the alloys used to match the coefficients of expansion of carbon and low alloy steels, grey and low alloy cast iron, ferritic stainless steels, and some nickel-base alloys. The data in *Figure 16* indicate that by varying the nickel content of Ni-Resist D-3 a range of coefficients of expansion will exist. Similar data have been produced for Ni-Resist 3. Thus, many of these dissimilar alloys can become closely compatible.

Low expansion

Where low thermal expansion is required for dimensional stability in machine tools, scientific instruments, glass molds and forming dies, Ni-Resist alloys 5, D-5, D-5B and D-5S are used. A high level of galling resistance and good machinability are added advantages. Ni-Resists D-5B and D-5S also have excellent oxidation resistance and mechanical properties

Table 23 Typical electrical resistivity of various alloys	
Alloy	Electrical resistivity nΩ.m
Ni-Resist D-2	1.02
Flake graphite Ni-Resist (1, 1B, 2, 2B)	1.30-1.70
Grey cast iron	0.75-1.00
Medium carbon steel	0.18
Type 410	0.57
Type 304	0.70

Table 24 Typical magnetic permeability of some Ni-Resists and other alloys	
Alloy	
Ni-Resist D-2	1.02
Ni-Resist D-2B	1.05
Ni-Resist D-2C	1.02
Ni-Resist D-2M	1.02
Ni-Resist D-4	1.10
Flake graphite Ni-Resist (1, 1B, 2, 2B)	1.03-1.05
Grey cast iron	125
Plain carbon steel	150
Type 410	Ferromagnetic
Type 304	<1.001
Aluminium bronze	<1.001

combined with low distortion at elevated temperatures. As an additional aid in diminishing distortion, ambient temperature stability heat treatment on page 14 should be used.

Thermal shock resistance

Because the strength and toughness of the spheroidal graphite Ni-Resists are superior to similar properties of the flake graphite alloys, the thermal shock resistance is also superior. In most cases involving temperature changes of up to 225 °C (400 °F), Ni-Resist D-3 can be used. However, where the thermal shock is known to be unusually severe, such as cycling between 500 and 1050 °C (930 and 1930 °F) Ni-Resist D-5S is the desired selection. This is particularly true because of its combination of oxidation resistance, ductility, hot strength, and low expansion coefficient.

Electrical resistivity

As can be seen from *Tables 7* and *8* the electrical resistivities of the flake graphite alloys are higher than for the corresponding ductile ones. *Table 23* shows they are also higher than the values for grey cast iron and carbon and stainless steels. This property is advantageous in certain electrical applications, especially in switches.

Magnetic properties

The magnetic permeabilities of some ductile Ni-Resists compared to other alloys are given in *Table 24*. Ni-Resist alloys D-2 and D-2C have been used in many non-magnetic applications. However, the only truly non-magnetic grades are Ni-Resists NiMn 13-7 and D-6. This property combined with their relatively good castability make them useful materials.

FIELDS OF APPLICATION

Throughout the text, numerous examples of applications of Ni-Resist alloys have been mentioned. In this section, we have grouped them by industry area and have included some additional uses. There are also several pictures of finished and unfinished castings intended for various applications.

Chemical processing

Chemical equipment requires the ability to withstand long periods of service under a wide variety of corrosive conditions. For those applications in chemical plants where cast components are suitable and economical, the Ni-Resist alloys are widely and successfully used.

Some of the more frequent applications are:

- Blowers
- Compressors
- Condenser parts
- Cryogenic equipment
- Furnace parts
- Piping

Pump impellers and vertical parts. Pumps made from these parts were for marine service, but they could have been used in many different environments and industries. Ni-Resist D-2C.

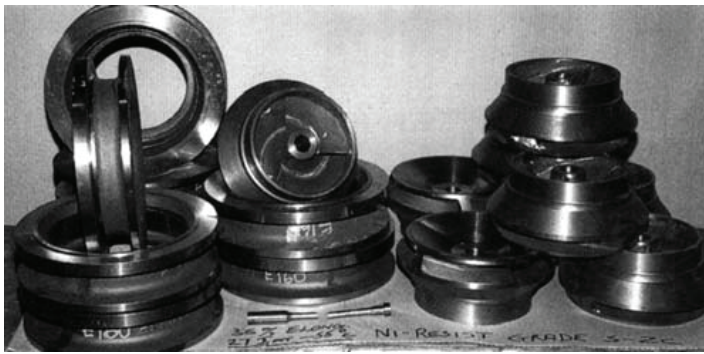

The Taylor Group, Larbert, U.K.

Stator for an electric generator. 2.5 m (100 in) dia. 2800 kg (6200 lbs). Ni-Resist D-6



H. Downs

- Pots and kettles
- Pump casings and impellers
- Rolls and conveyors
- Salt solution and slurry handling equipment
- Valves and valve fittings

Electrical power industry

Increases in the demand for electricity and the need to replace old and obsolete generating facilities mean that engineers and designers must devise means for increasing the efficiency of power production. Thus, higher pressures, higher operating temperatures and other requirements mean demands for better materials of construction. In many cases, the Ni-Resist family of alloys provide economical and efficient answers. For example, application opportunities include equipment for generation, transmission and utilisation of electricity derived from gasoline and diesel engines as well as from steam, water, and gas-powered turbines.

Some of the more frequent applications are:

- Mechanical seals
- Meter parts
- Non-magnetic housings

Compressor housing for use with steam containing solid particles. Ni-Resist D-2C.

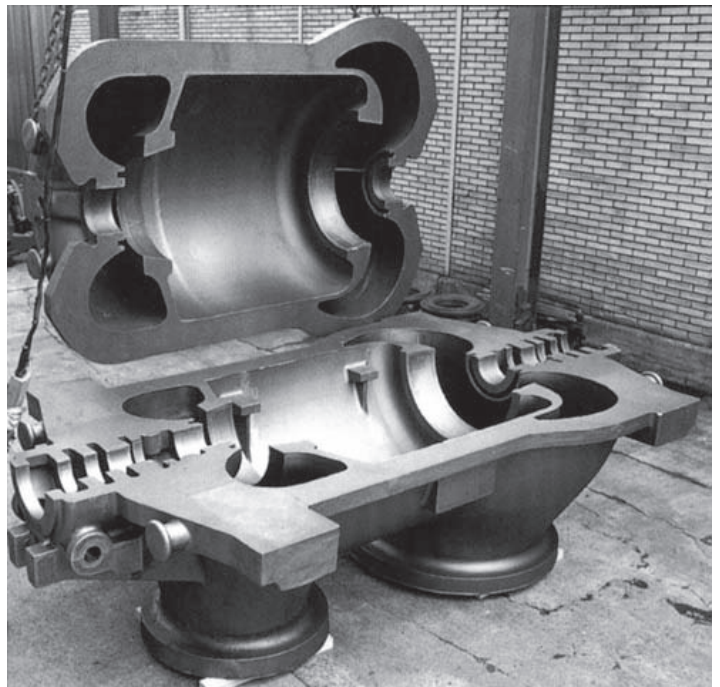

Macaulay Foundry, Berkeley, California, U.S.A.

- Pole line hardware
- Pump casings, diffusers, and impellers
- Resistance grids
- Steam handling equipment
- Switch parts
- Turbine parts
- Valves and related attachments

Food handling and processing

Sanitation is necessary in all food processing equipment that comes in contact with the product. Corrosion must be minimised, and cleaning must be quick and thorough. For equipment that lends itself to castings, Ni-Resist alloys have given very satisfactory service. Prevention of contamination or discolouration of food is often achieved using Ni-Resists 2, 2b, 3 or 4 and their ductile counterparts in pumps, kettles, filters and valves. Ni-Resist 4 provides advantages in quality cooking, with little warping or pitting. Food does not stick to utensils, pots, or grills. Cooking equipment made with this alloy are easy to keep clean and remain smooth, bright, and attractive.

Some of the more frequent applications are:

- Baking, bottling and brewing equipment
- Canning machinery
- Distillery equipment

Exhaust gas diffuser for stationary gas turbine used for generation of electricity. Weight - 235 kgs (520 lbs). Ni-Resist D-2B.

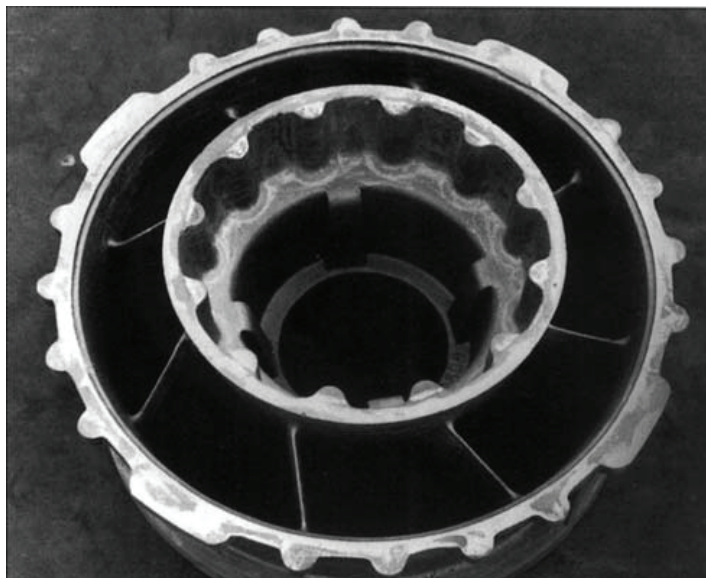

Sulzer-Escher Wyss, Zurich, Switzerland

- Feed screws
- Fish processing equipment
- Heavy duty range tops and grills
- Meat grinders, chopper and packing equipment
- Pots and kettles
- Pumps and pump parts
- Salt solution filters

Internal combustion engines

The Ni-Resist alloys have certain outstanding advantages in this field. They are used in gasoline, diesel and LPG powered engines in trucks, busses, railway locomotives, stationary power plants and marine and aircraft propulsion units.

For exhaust parts such as manifolds and valve guides, Ni-Resist castings have proved resistant to the effects of temperatures up to 1050 °C (1930 °F) and the severe wear that can be caused by valve stem motion. They are also resistant to attack by most usual combustion products. Thermal expansion coefficients of Ni-Resist alloys which closely match those of stainless steels and UNS N06600 are another factor in exhaust applications.

Cylinder heads of Ni-Resist alloys resist corrosion from water and combustion products and have good metal-to-metal wear behaviour. Ni-Resist finds widespread use as insert rings in aluminium alloy pistons. Water pump impellers and bodies

Turbine manifolds and housings for automotive gasoline powered engines. Ni-Resist D-5S.



Duport Harper Foundries Ltd., Tipton, U.K.

offer another appropriate use for Ni-Resist alloys in engines. With increases in power, modern water pumps must operate at higher velocities than in the past. Higher water temperatures and pressures may increase the corrosion hazard and higher speeds can cause increased erosion damage.

Some of the more frequent applications are:

- Cylinder liners
- Diesel engine exhaust manifolds
- Exhaust valve guides
- Gas turbine housings, stators and other parts
- Insert rings and hot spot buttons for aluminium alloy pistons

Liquid handling: Rotating filter drum for a freshwater treatment plant. Weight 106 kgs (234 lbs). Ni-Resist 2.

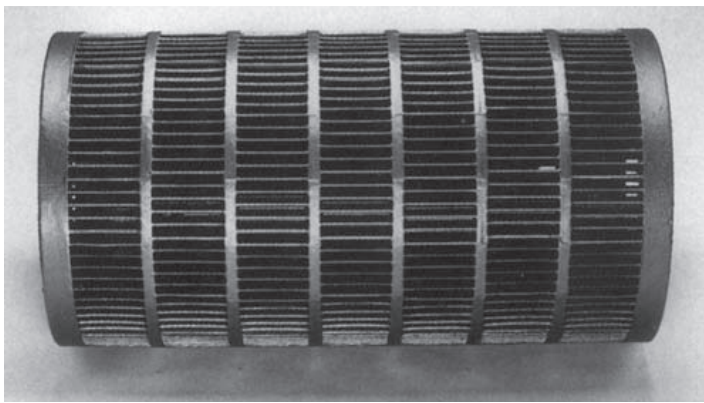

Taylor & Fenn Company, Windsor, Connecticut U.S.A.

Discharge evaporator elbow for triple effect evaporators for the potash industry. Weight 2900 kgs (6400 lbs) Ni-Resist D-2B



Highland Foundry

- Turbocharger housings, nozzle rings, heat shields and other parts
- Water pump bodies and impellers

Liquid handling

The same characteristics that have made the Ni-Resist alloys so valuable in the chemical and process industries apply to many other areas where corrosive liquids and erosive conditions exist.

Some of the more frequent applications are:

- Diffuser housings
- Pumps and pump parts
- Steam ejectors
- Mechanical seals
- Strainers
- Pipe and pipe fittings
- Valves of all kinds

Marine industry

The corrosion and erosion resistance of Ni-Resist alloys in seawater have made these materials exceptionally useful for a broad range of applications where seawater is encountered.

Pump volute or spiral outlet casting. Weight 2090 kgs (4600 lbs). Ni-Resist 1.

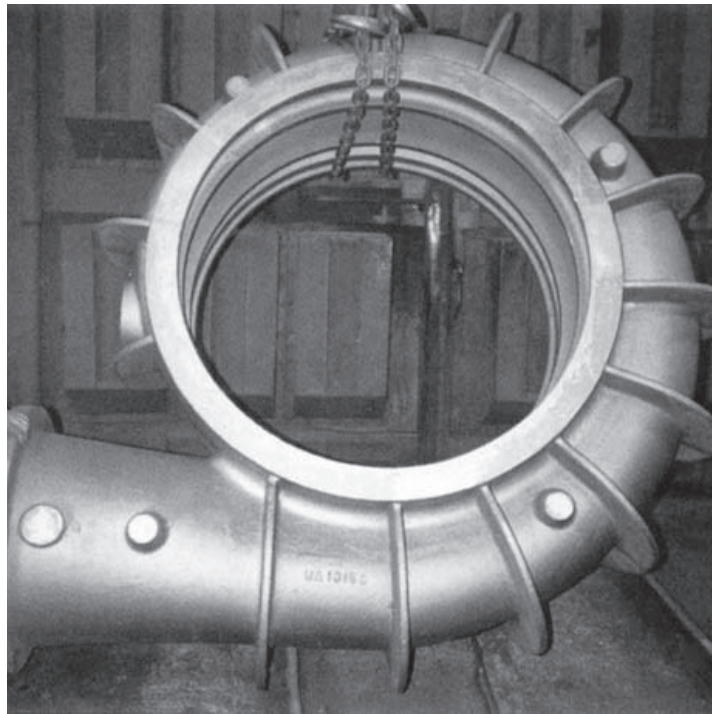

St. Mary's Foundry, St. Mary's, Ohio, U.S.A.

Some of the more frequent applications are:

- Diesel engine manifolds
- Miscellaneous hardware
- Pipe and pipe fittings
- Pumps and pump parts
- Strainers
- Valves and valve parts

Petroleum industry

When petroleum fluids enter feed lines, refineries, and other processing plants, they must be distributed to the processing equipment. In addition, large quantities of water are often required in the various operations. In all of this, corrosion-resistant materials are needed. For cast parts, Ni-Resist alloys have proved to be very successful. They have good corrosion resistance to saltwater, corrosive petroleum fractions and some of the milder acids and caustics often encountered.

Some of the more frequent applications are:

- Deep well, acid water and water flood pumps
- Gas compressors
- Motor parts
- Pipe and pipe fittings
- Petroleum fluids pumps and pump parts
- All kinds of valves and valve parts

Bowl section for a large seawater pump. Weight 2000 kgs (4400 lbs). Ni-Resist D-2W.

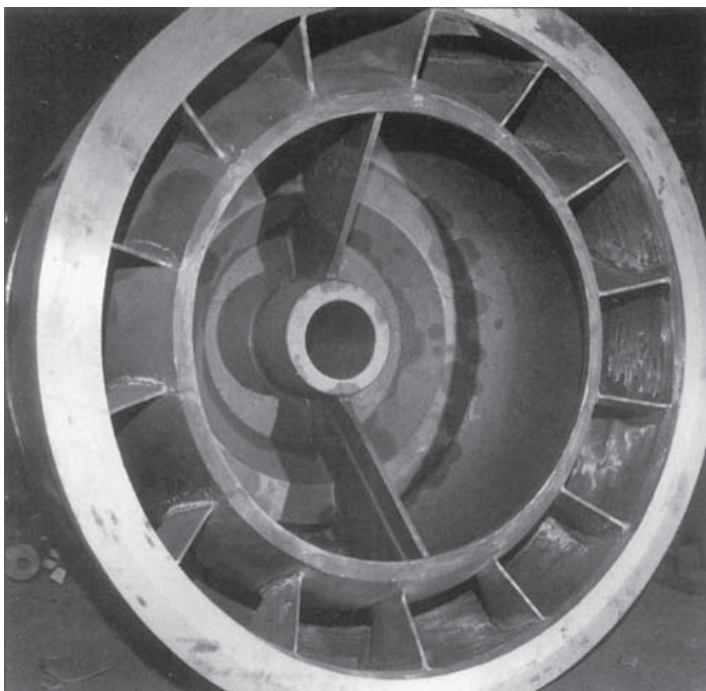

The Taylor Group, Larbert, U.K.

Precision machinery

Because of their low coefficients of thermal expansion, Ni-Resists 5 and D-5 are the primary cast alloys used where dimensional stability is a requirement. The accuracy of many machine tools, gauges and instruments may be increased by using them in vital parts. The coefficient of thermal expansion of these Ni-Resist alloys is one-third of that for grey cast iron. Ni-Resist D-5 is considerably tougher. Both alloys are more corrosion resistant and they are comparable with regard to vibration damping capacity and machinability.

Some of the more frequent applications are:

- Bases, bridges and work supports
- Forming dies
- Gauges
- Glass molds
- Instrument parts
- Machine tool ways
- Measuring tools
- Optical parts
- Spindle housings

Plug valve intended for pulp and paper plant service. Valves of this type are used in many liquid handling systems in various industries. Ni-Resist 2.

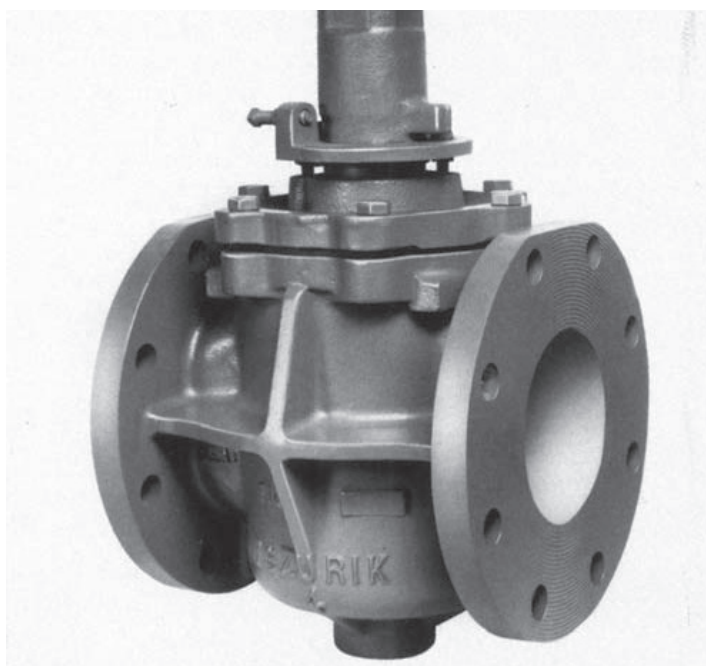

DeZurik Division of General Signal, Sartell, Minnesota, U.S.A.

Pulp and paper industry

Corrosion is a problem at practically all stages in the manufacture of pulp and paper. The sulphite process has acid conditions. Kraft mills have alkaline environments. A combination of corrosion and erosion exists in both types of plants. Ni-Resist alloys offer useful solutions in many areas.

Some of the more frequent applications are:

- Dryer rolls
- Grids
- Press rolls
- Screen runners
- Wood steamers
- Fourdrinier castings
- Pipe and pipe fittings
- Pumps and pump parts
- Spiders valves and valve parts

Miscellaneous applications

The above listings of applications within particular industries are only a beginning where Ni-Resist alloys are concerned. As a class, the Ni-Resists are a very versatile group and can be found in almost any field. In order to emphasise this, we have included pictures of Ni-Resist products which are not easily categorised but have both widespread and unique uses.

Discharge evaporator elbow for triple effect evaporators for the potash industry. Weight 2900 kgs (6400 lbs) Ni-Resist D-2B

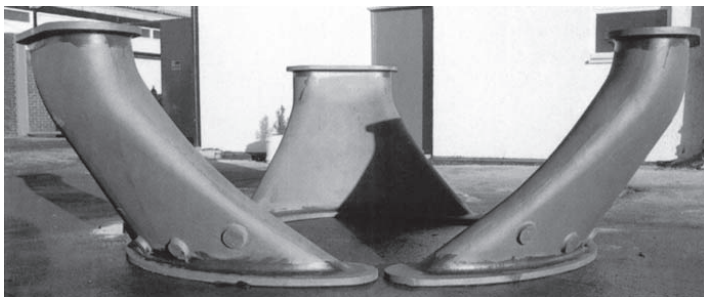

PART II NATIONAL AND INTERNATIONAL STANDARDS

The following tables indicate the designations for ASTM, ISO, European (EN) and Japanese standards and for the withdrawn national standards in Australia, France, Germany and the United Kingdom.

COMPARISON OF INTERNATIONAL AND NATIONAL STANDARDS COVERING AUSTENITIC CAST IRON

Flake graphite austenitic cast iron grades				
Equivalent Ni-Resist grades	United States ASTM A436-84 (2020)	International ISO 2892-2007	Europe EN 13835:2012	Japan JIS G 5510-2012
-	-	L-NiMn 13 7	GJLA-XNiMn 13 7	FCA-NiMn 13 7
1	Type 1	L-NiCuCr 15 6 2	GJLA-XNiCuCr 15 6 2	FCA-NiCuCr 15 6 2
1b	Type 1b	L-NiCuCr 15 6 3	-	FCA-NiCuCr 15 6 3
2	Type 2	L-NiCr 20 2	-	FCA-NiCr 20 2
2b	Type 2b	L-NiCr 20 3	-	-
-	-	L-NiSiCr 20 5 3	-	FCA-NiSiCr 20 5 3
3	Type 3	L-NiCr 30 3	-	-
4	Type 4	L-NiSiCr 30 5 5	-	FCA-NiSiCr 30 5 5
5	Type 5	L-Ni35	-	FCA-Ni 35
6	Type 6	-	-	-

Spheroidal graphite (ductile) austenitic cast iron grades				
Equivalent ductile Ni-Resist grades	United States ASTM A439-2018 ASTM A571-01 (2019)	International ISO 2892-2007	Europe EN 13835:2012	Japan JIS G 5510-2012
D-2	D-2	S-NiCr 20 2	GJSA-XNiCr 20 2	FCDA-NiCr 20 2
D-2W	-	-	GJSA-XNiCrNb 20 2	FCDA-NiCrNb 20 2
D-2B	D-2B	S-NiCr 20 3	-	FCDA-NiCr 20 3
Nicosital Spheronic	-	S-NiSiCr 20 5 2	-	-
D-2C	D-2C	S-Ni 22	GJSA-XNi 22	FCDA-Ni 22
D-2M	D-2M	S-NiMn 23 4	GJSA-XNiMn 23 4	FCDA-NiMn 23 4
	D-2S	-	-	-
D-3	D-3	S-NiCr 30 3	GJSA-XNiCr 30 3	FCDA-NiCr 30 3
D-3A	D-3A	S-NiCr 30 1	-	FCDA-NiCr 30 1
D-4	D-4	S-NiSiCr 30 5 5	GJSA-XNiSiCr 30 5 5	FCDA-NiSiCr 30 5 5
D-4A	-	-	-	-
D-5	D-5	S-Ni 35	GJSA-XNi 35	FCDA-Ni 35
D-5B	D-5B	S-NiCr 35 3	GJSA-XNiCr 35 3	FCDA-NiCr 35 3
D-5S	D-5S	S-NiSiCr 35 5 2	GJSA-XNiSiCr 35 5 2	FCDA-NiSiCr 35 5 2
D-6	-	S-NiMn 13 7	GJSA-XNiMn 13 7	FCDA-NiMn 13 7

Specified composition and mechanical property limits for the above specifications are in the following pages.

Each specification has its own maximum and minimum limits, and these frequently are at variance with other specifications for "the same" alloy.

Specifications are from time to time revised, which can result in changes to permitted limits.

	Australia AS 1833-2002 (withdrawn)	France NF A32-301-1992 (withdrawn)	Germany DIN 1694-1981 (withdrawn)	United Kingdom BS 3468-1986 (withdrawn)
	L-NiMn 13 7	FGL-Ni13 Mn7	GGL-NiMn 13 7	-
	L-NiCuCr 15 6 2	FGL-Ni15 Cu6 Cr2	GGL-NiCuCr 15 6 2	F1
	L-NiCuCr 15 6 3	FGL-Ni15 Cu6 Cr3	GGL-NiCuCr 15 6 3	-
	L-NiCr 20 2	FGL-Ni20 Cr2	GGL-NiCr 20 2	F2
	L-NiCr 20 3	FGL-Ni20 Cr3	GGL-NiCr 20 3	-
	L-NiSiCr 20 5 3	FGL-Ni20 Si5 Cr3	GGL-NiSiCr 20 5 3	-
	L-NiCr 30 3	FGL-Ni30 Cr3	GGL-NiCr 30 3	F3
	L-NiSiCr 30 5 5	FGL-Ni30 Si5 Cr5	GGL-NiSiCr 30 5 5	-
	L-Ni 35	FGL-Ni 35	-	-
	-	-	-	-

	Australia AS 1833-2002 (withdrawn)	France NF A32-301-1992 (withdrawn)	Germany DIN 1694-1981 (withdrawn)	United Kingdom BS 3468-1986 (withdrawn)
	S-NiCr 20 2	FGS-Ni20 Cr 2	GGG-NiCr 20 2	S2
	-	FGS-Ni20 Cr2Nb0.15	GGG-NiCrNb 20 2	S2W
	S-NiCr 20 3	FGS-Ni20 Cr 3	GGG-NiCr 20 3	S2B
	S-NiSiCr 20 5 2	FGS-Ni20 Si5 Cr 2	GGG-NiSiCr 20 5 2	-
	S-Ni 22	FGS-Ni22	GGG-Ni 22	S2C
	S-NiMn 23 4	FGS-Ni 23 Mn 4	GGG-NiMn 23 4	S2M
	-	-	-	-
	S-NiCr 30 3	FGS-Ni30 Cr3	GGG-NiCr 30 3	S3
	S-NiCr 30 1	FGS-Ni30 Cr 1	GGG-NiCr 30 1	-
	S-NiSiCr 30 5 5	FGS-Ni30 Si5 Cr5	GGG-NiSiCr 30 5 5	-
	-	FGS-Ni30 Si5 Cr2	GGG-NiSiCr 30 5 2	-
	S-Ni 35	FGS-Ni35	GGG-Ni 35	-
	S-NiCr 35 3	FGS-Ni35 Cr3	GGG-NiCr 35 3	-
	-	FGS-Ni35 Si5 Cr2	GGG-NiSiCr 35 5 2	S5S
	S-NiMn 13 7	FGS-Ni13 Mn7	GGG-NiMn 13 7	S6

Before using any standard, it is advisable to check the current revision for details.

French, German and UK specifications have been replaced by the EN European standard

TABLES OF SPECIFICATIONS

United States A-1 Flake Graphite Grades, Chemical Composition A-2 Flake Graphite, Mechanical Properties A-3 Spheroidal Graphite Grades, Chemical Composition A-4 Spheroidal Graphite, Mechanical Properties
International Organisation for Standardisation, ISO B-1 Flake Graphite Grades, Chemical Composition and Mechanical Properties B-2 Spheroidal Graphite (Ductile) Grades, Chemical Composition B-3 Spheroidal Graphite (Ductile) Grades, Mechanical Properties
European Standard5 Engineering Grades C-1 Flake Graphite and Spheroidal Graphite, Chemical Composition C-2 Flake Graphite and Spheroidal Graphite, Mechanical Properties Special Purpose Grades C-3 Flake Graphite and Spheroidal Graphite, Chemical Composition C-4 Flake Graphite and Spheroidal Graphite, Mechanical Properties

UNITED STATES

A-1 Flake graphite grades – Composition (Single values are maximums) ASTM A436-84 (2020)								
	C %	Si %	Mn %	Ni %	Cu %	Cr %	S %	Mo %
Type 1	3.00	1.00-2.80	0.5-1.5	13.50-17.50	5.50-7.50	1.50-2.50	0.12	–
Type 1b	3.00	1.00-2.80	0.5-1.5	13.50-17.50	5.50-7.50	2.50-3.50	0.12	–
Type 2	3.00	1.00-2.80	0.5-1.5	18.00-22.00	0.50	1.50-2.50	0.12	–
Type 2b	3.00	1.00-2.80	0.5-1.5	18.00-22.00	0.50	3.00-6.00 ^A	0.12	–
Type 3	2.60	1.00-2.00	0.5-1.5	28.00-32.00	0.50	2.50-3.50	0.12	–
Type 4	2.60	5.00-6.00	0.5-1.5	29.00-32.00	0.50	4.50-5.50	0.12	–
Type 5	2.40	1.00-2.00	0.5-1.5	34.00-36.00	0.50	0.10 max.	0.12	–
Type 6	3.00	1.50-2.50	0.5-1.5	18.00-22.00	3.50-5.50	1.00-2.00	0.12	1.00

A – Where some machining is required, the 3.00-4.00% Cr range is recommended.

A-2 Mechanical properties, flake graphite grades, ASTM A436-84 (2020)		
	Tensile strength min. ksi (MPa)	Brinell hardness (HB) (3000kg)
Type 1	25 (172)	131-183
Type 1b	30 (207)	149-212
Type 2	25 (172)	118-174
Type 2b	30 (207)	171-248
Type 3	25 (172)	118-159
Type 4	25 (172)	149-212
Type 5	20 (138)	99-124
Type 6	25 (172)	124-174

A-3 Spheroidal graphite grades – Composition (Single values are maximums) ASTM A439-18, D-2M-ASTM A571-01 (2019)						
	C %	Si %	Mn %	Ni %	Cr %	P %
D-2 ^A	3.00	1.50-3.00	0.70-1.25	18.00-22.00	1.75-2.75	0.08
D-2B	3.00	1.50-3.00	0.70-1.25	18.00-22.00	2.75-4.00	0.08
D-2C	2.90	1.00-3.00	1.80-2.40	21.00-24.00	0.50 max. ^B	0.08
D-2M	2.2-2.7 ^C	1.50-2.50	3.75-4.50	21.00-24.00	0.20 max. ^B	0.08
D-2S	2.60	4.80-5.80	1.00 max. ^B	24.00-28.00	1.75-2.25	0.08
D-3 ^A	2.60	1.00-2.80	1.00 max. ^B	28.00-32.00	2.50-3.50	0.08
D-3A	2.60	1.00-2.80	1.00 max. ^B	28.00-32.00	1.00-1.50	0.08
D-4	2.60	5.00-6.00	1.00 max. ^B	28.00-32.00	4.50-5.50	0.08
D-5	2.40	1.00-2.80	1.00 max. ^B	34.00-36.00	0.10 max.	0.08
D-5B	2.40	1.00-2.80	1.00 max. ^B	34.00-36.00	2.00-3.00	0.08
D-5S	2.30	4.90-5.50	1.00 max. ^B	34.00-37.00	1.75-2.25	0.08

A – Additions of 0.7-1.0% Mo will increase the mechanical properties above 425 °C (800 °F)
 B – Not intentionally added
 C – For casting with sections under 6 mm (0.25 in.), it may be desirable to adjust the carbon upwards to a max. of 2.90%

A-4 Mechanical properties, spheroidal graphite grades, ASTM A439/A439M-18, D-2M-ASTM A571/A571M-01 (2019)						
	Tensile strength min. ksi (MPa)	Yield strength, 0.2% offset, min. ksi (MPa)	Elongation, in 2" or 50 mm, min%	Brinell hardness, (HB) 3000 g	Charpy V-notch ^D , ft-lbf (J)	
					min. avg. 3 tests	min. ind. test
D-2	58 (400)	30 (210)	8.0	139-202	-	-
D-2B	58 (400)	30 (210)	7.0	148-211	-	-
D-2C	58 (400)	28 (195)	20.0	121-171	-	-
D-2M CI 1	65 (450)	30 (205) ^B	30.0	121-171	15 (20)	12 (16) ^C
D-2M CI 2	60 (415)	25 (170) ^B	25.0	111-171	20 (27)	15 (20) ^C
D-2S	55 (380)	30 (210)	10.0	131-193	-	-
D-3 ^A	55 (380)	30 (210)	6.0	139-202	-	-
D-3A	55 (380)	30 (210)	10.0	131-193	-	-
D-4	60 (415)	-	-	202-273	-	-
D-5	55 (380)	30 (210)	20.0	131-185	-	-
D-5B	55 (380)	30 (210)	6.0	139-193	-	-
D-5S	55 (380)	30 (210)	10.0	131-193	-	-

A – Heat-treated condition
 B – Yield strength shall be determined at 0.2% offset method, see Test Methods E8. Other methods may be agreed upon by mutual consent of the manufacturer and purchaser.
 C – Not more than one test in a set of three may be below the min. average required for the set of three.
 D – The energy absorption values shown are applicable at temperatures down to and including -196 °C.

INTERNATIONAL ORGANISATION FOR STANDARDISATION

B-1 Flake graphite grades – Composition, ISO 2892-2007 (2020)							
Alloy grade	C % max.	Si %	Mn %	Ni %	Cu %	Cr %	Tensile strength (R _m) min. MPa
L-NiMn 13 7	3.0	1.5–3.0	6.0–7.0	12.0–14.0	0.5 max.	0.2 max.	140
L-NiCuCr 15 6 2	3.0	1.0–2.8	0.5–1.5	13.5–17.5	5.5–7.5	1.0–2.5	170
L-NiCuCr 15 6 3	3.0	1.0–2.8	0.5–1.5	13.5–17.5	5.5–7.5	2.5–3.5	190
L-NiCr 20 2	3.0	1.0–2.8	0.5–1.5	18.0–22.0	0.5 max.	1.0–2.0	170
L-NiCr 20 3	3.0	1.0–2.8	0.5–1.5	18.0–22.0	0.5 max.	2.5–3.5	190
L-NiSiCr 20 5 3	2.5	4.5–5.5	0.5–1.5	18.0–22.0	0.5 max.	1.5–4.5	190
L-NiCr 30 3	2.5	1.0–2.0	0.5–1.5	28.0–32.0	0.5 max.	2.5–3.5	190
L-NiSiCr 30 5 5	2.5	5.0–6.0	0.5–1.5	29.0–32.0	0.5 max.	4.5–5.5	170
L-Ni 35	2.4	1.0–2.0	0.5–1.5	34.0–36.0	0.5 max.	0.2 max.	120

B-2 Spheroidal graphite (ductile) grades – Composition, ISO 2892-2007 (2020) (single values are maximums)							
Alloy grade	C %	Si %	Mn %	Ni %	Cu %	Cr %	
S-NiMn 13 7	3.0	2.0–3.0	6.0–7.0	12.0–14.0	0.5	0.2	
S-NiCr 20 2	3.0	1.5–3.0	0.5–1.5	18.0–22.0	0.5	1.0–2.5	
S-NiCr 20 3	3.0	1.5–3.0	0.5–1.5	18.0–22.0	0.5	2.5–3.5	
S-NiSiCr 20 5 2	3.0	4.5–5.5	0.5–1.5	18.0–22.0	0.5	1.0–2.5	
S-Ni 22	3.0	1.0–3.0	1.5–2.5	21.0–24.0	0.5	0.5	
S-NiMn 23 4	2.6	1.5–2.5	4.0–4.5	22.0–24.0	0.5	0.2	
S-NiCr 30 1	2.6	1.5–3.0	0.5–1.5	28.0–32.0	0.5	1.0–1.5	
S-NiCr 30 3	2.6	1.5–3.0	0.5–1.5	28.0–32.0	0.5	2.5–3.5	
S-NiSi Cr 30 5 5	2.6	5.0–6.0	0.5–1.5	28.0–32.0	0.5	4.5–5.5	
S-Ni 35	2.4	1.5–3.0	0.5–1.5	34.0–36.0	0.5	0.2	
S-NiCr 35 3	2.4	1.5–3.0	0.5–1.5	34.0–36.0	0.5	2.0–3.0	

B-3 Spheroidal graphite (ductile) grades – Mechanical properties, ISO 2892-2007 (2020)					
Alloy grade	Tensile strength (R _m) min. MPa	0.2% Proof stress (R _{p0.2}) min. MPa	Elongation (A) min. %	Minimum mean impact value on 3 tests	
				V-notch (Charpy) J	U-notch (Mesnager) J
S-NiMn 13 7	390	210	15	16	-
S-NiCr 20 2	370	210	7	13	16
S-NiCr 20 3	390	210	7	-	-
S-NiSiCr 20 5 2	370	210	10	-	-
S-Ni 22	370	170	20	20	24
S-NiMn 23 4	440	210	25	24	28
S-NiCr 30 1	370	210	13	-	-
S-NiCr 30 3	370	210	7	-	-
S-NiSiCr 30 5 5	390	240	-	-	-
S-Ni 35	370	210	20	-	-
S-NiCr 35 3	370	210	7	-	-

A -1J=1N-m

EUROPEAN STANDARD

C-1 Engineering grades – Composition, EN 13835-2012 (single values are maximums)								
Graphite form	Designation Grade	C %	Si %	Mn %	Ni %	Cr %	P %	Cu %
Flake	EN-GJLA-XNiCuCr 15 6 2	3.0	1.0–2.8	0.5–1.5	13.5–17.5	1.0–3.5	0.25	5.5–7.5
Spheroidal	EN-GJSA-XNiCr 20 2	3.0	1.5–3.0	0.5–1.5	18.0–22.0	1.0–3.5	0.08	0.50
	EN-GJSA-XNiMn 23 4	2.6	1.5–2.5	4.0–4.5	22.0–24.0	0.2	0.08	0.50
	EN-GJSA-XNiCrNb 20 2 2 (1)	3.0	1.5–2.4	0.5–1.5	18.0–22.0	1.0–3.5	0.08	0.50
	EN-GJSA-XNi 22	3.0	1.0–3.0	1.5–2.5	21.0–24.0	0.5	0.08	0.50
	EN-GJSA-XNi 35	2.4	1.5–3.0	0.5–1.5	34.0–36.0	0.2	0.08	0.50
	EN-GJSA-XNiSiCr 35 5 2	2.0	4.0–6.0	0.5–1.5	34.0–36.0	1.5–2.5	0.08	0.50

(1) For good weldability of this material Nb% $\leq 0.353 - 0.032(\text{Si}\% + 64 \cdot \text{Mg}\%)$ (Typical niobium addition 0.12 – 0.18%)

C-2 Engineering grades – Mechanical properties, EN 13835-2012					
Graphite form	Designation grade	Tensile strength (R _m) min. MPa	0.2 % Proof strength (R _{p0.2}) min. MPa	Elongation (A) min %	Minimum mean impact value on 3 tests V notch Charpy (J)
Flake	EN-GJLA-XNiCuCr 15 6 2	170	-	-	-
Spheroidal	EN-GJSA-XNiCr 20 2	370	210	7	13*
	EN-GJSA-XNiMn 23 4	440	210	25	24
	EN-GJSA-XNiCrNb 20 2	370	210	7	13*
	EN-GJSA-XNi 22	370	170	20	20
	EN-GJSA-XNi 35	370	210	20	23
	EN-GJSA-XNiSiCr 35 5 2	370	200	10	-

* Optional requirement by agreement with the customer.

C-3 Special purpose grades – Composition, EN 13835-2012								
Graphite form	Designation grade	C max. %	Si %	Mn %	Ni %	Cr %	P max. %	Cu max. %
Flake	EN-GJLA-XNiMn 13 7	3.0	1.5–3.0	6.0–7.0	12.0–14.0	0.2 max.	0.25	0.50
Spheroidal	EN-GJSA-XNiMn 13 7	3.0	2.0–3.0	6.0–7.0	12.0–14.0	0.2 max.	0.08	0.50
	EN-GJSA-XNiCr 30 3	2.6	1.5–3.0	0.5–1.5	28.0–32.0	2.5–3.5	0.08	0.50
	EN-GJSA-XNiSiCr 30 5 5	2.6	5.0–6.0	0.5–1.5	28.0–32.0	4.5–5.5	0.08	0.50
	EN-GJSA-XNiCr 35 3	2.4	1.5–3.0	0.5–1.5	34.0–36.0	2.0–3.0	0.08	0.50

C-4 Special purpose grades – Mechanical properties, EN 13835-2012					
Graphite form	Designation grade	Tensile strength (R _m) min MPa	0.2% Proof stress (R _{p0.2}) min. MPa	Elongation (A) min. %	Minimum mean impact value on 3 tests V notch Charpy (J)
Flake	EN-GJLA-XNiMn 13 7	140	-	-	-
Spheroidal	EN-GJSA-XNiMn 13 7	390	210	15	16
	EN-GJSA-XNiCr 30 3	370	210	7	-
	EN-GJSA-XNiSiCr 30 5 5	390	240	-	-
	EN-GJSA-XNiCr 35 3	370	210	7	-

PART III CORROSION DATA

Selected results from service and laboratory tests comparing Ni-Resist with cast iron for a variety of conditions. This data was generated many years ago at International Nickel through laboratory testing and field coupon rack tests. Note: "1 mil = 0.001 inch"; "4 mils per year = 0.1 mm/yr"

Corrosive medium	Location of test specimens	Duration of test	Temperature °F
Acetic acid, 10%	Laboratory		60
Acetic acid, 25%	Laboratory		60
Acetic acid, 25% (by vol.)	Laboratory	168 hours	68
Acetic acid, 25% (by vol.)	Laboratory	600 hours	68
Acetic acid, concentrated	Laboratory		60
Acetic acid, 47%; 24% NaCl; some Oleic acid and oxidising salts	Recirculating tank	23 days	100
Acetone, 10 parts, and one part Oleic acid - Linoleic acid mixture	Solvent recovery still	150 hours	145
Acetone, 5 parts, and one part Oleic acid - Linoleic acid mixture	Separator tank	131 days	35.6 for 102 days 68.0 for 150 hours
Acetylene tetrachloride, trichlorethylene vapour, lime	In still	30 days	210
Aluminium sulphate, 57% (at end); 0.02% Ferric, and 0.8% Ferrous sulphate	Alum evaporator	44 days	140-240
Aluminium sulphate, 2%/gal.	Alum storage tank	62 days	90-98
Aluminium sulphate, 5%	Laboratory		60
Aluminium sulphate, 0.1%	Laboratory		60
Ammonium hydroxide, 5%	Laboratory		60
Ammonium hydroxide, 10%	Laboratory		60
Ammonium hydroxide, 25%	Laboratory		60
Ammonia solution, 50%	Laboratory		60
Ammonia solution, 75%	Laboratory		60
Ammonia solution, concentrated	Laboratory		60
Ammonia, 5-6% by vol.; 150 ppm.; Phenol carried by water vapour	Top of phenol tower	309 days	215.6
Ammonia liquors of 10 g/l Ammonia	Inside ammonia coils	318 days	77
Ammonia liquors of 10 g/l Ammonia	Inside ammonia coils	318 days	158
Ammonia liquor	Ammonia liquor separator tank	225 days	
Ammonia liquors of 6.5 g/l Ammonia	Liquor balance tank	307 days	215.6
Ammonia liquors carrying sulphates, sulphides, etc.	Feed tank	449 days	100
Ammonium chloride, 5%	Laboratory		60
Ammonium chloride, 5%	Laboratory		200
Ammonium chloride, 10%	Laboratory		60
Ammonium chloride, 10%	Laboratory		200
Ammonium chloride, 20%	Laboratory		60
Ammonium chloride, 20%	Laboratory		200

	Aeration	Velocity	Average corrosion rates mils per year		Type Ni-Resist iron preferred
			Cast iron	Ni-Resist iron	
	Some		880	20	1-2
	Some		790	20	1-2
		None	*	1	1-2
		None	*	2	1-2
	Some		80	20	1-2
			20	4	1-2
	None	Natural ebullition	20	Gained weight	1-2
	None	None	0.4	0.6	1-2
	None	Boiling	70	4	1-2
			*	300	Not resistant
			*	4	1
	Some		40	16	1
	Same		5	2	1
			No loss	0.1	1-2-3
			No loss	0.2	1-2-3
			No loss	0.18	1-2-3
			No loss	No loss	1-2
			No loss	No loss	1-2
			2	No loss	1-2
	None	750,000 cu.ft/hr	2	0.9	1-2
		By flow		0.2	1-2
		By flow		6	1-2
			0.09	0.05	1-2
	None	1500 gal/hr	3	0.6	1-2
	Slight	By flow	0.1	0.1	1-2
	Some		50	3	1-2
	Some		190	6	1-2
	Some		40	7	1-2
	Some		210	6	1-2
	Some		50	10	1-2
	Some		230	3	1-2

Corrosive medium	Location of test specimens	Duration of test	Temperature °F	
Ammonium chloride 35%, Zinc chloride 35%. Slightly alkaline	Dissolving tank	59 days	Room to 225	
Ammonium chloride, 28-40%	Evaporating tank	762 hours	77-216	
Ammonium perchlorate 265-300 g/l- Sodium chloride 214-250 g/l, Sodium perchlorate 36 g/l, pH 5.2	Crystalliser	192 days	122	
Ammonium nitrate 66.8% + Ammonia 16.6% and Ammonium nitrate 55.5% + Ammonia 26%	Pump suction from mixing tank	36 days	120	
Ammonium and Sodium nitrate solution settled after shaking in the presence of the sample with NH ₃ gas until free NH ₃ was 80 g/l	Laboratory	0.33 hour	149	
Ammonium sulphate with 8% Sulphuric acid and Ammonia liquors	In a saturator drain table	99 days	150	
Ammonium sulphate, 5%	Laboratory		60	
Ammonium sulphate, 10%	Laboratory		60	
Ammonium sulphate, 25, %	Laboratory		60	
Saturated Ammonium sulphate in 3-10% H ₂ SO ₄ , plus coke oven gas	Saturator on "Cracker Pipe"	77 days	131	
Arsenic acid, 65%	Collection tank	21 days	80-120	
Benzene	Laboratory			
Benzol vapours and liquid	At bottom plate of fractionating column of benzol still	186 days		
Benzol vapours and liquid	At 24th plate from bottom of fractionating column of benzol still	186 days		
Benzol liquid	Still body	146 days		
Boron trichloride 95%, Chlorine 5%, traces of Aluminium chloride	Stripping column condenser	60 days	54	
Boron trichloride 99%, traces of Chlorine	Refining column condenser	67 days	55	
Calcium chloride, 5%	Laboratory		60	
Calcium chloride, 5%, plus Magnesium chloride, 5%	Laboratory		60	
Calcium chloride, 8%; Calcium bromide, 38%; Lithium, 11%; Bromide brine.	Dehumidifying of air	38 days	120	
Calcium chloride cooling brine with Potassium dichromate inhibitor	Brine tank	372 days		
Calcium chloride cooling brine	Brine tank	355 days		
Calcium-Sodium-Magnesium chloride brines in 28% concentration	Evaporator at liquor level	752.5 hours	160	
Calcium-Magnesium chloride brine; 50% total chlorides	Evaporator at liquor level	26 days	Boiling	
Calcium hydrosulphide containing 45-50 g/l CaO	Turbo gas absorber above impeller hood	46 days	139	
Calcium hydroxide, saturated solution	Laboratory	20 hours	86	
Calcium hydroxide (Lime water)	Laboratory		60	

* Ordinarily not satisfactory.

	Aeration	Velocity	Average corrosion rates mils per year		Type Ni-Resist iron preferred
			Cast iron	Ni-Resist iron	
	Air agitated	Agitated	150	10	1
			360	10	1-2
	Air free	Low		3.3	1
	Low	4.1 ft/sec	2.2	0.4	2
	NaHCO ₃ reacted with HN, NO ₂ to produce free NH ₃ and CO ₂ gas		120	10	1-2
	Aerated	Some	70	5	1
	Some		30	6	1
	Some		30	4	1
	Some		10	0.7	1
	None	Violent	80	2	1
	Exposed to air	Stagnant except when tank filled & emptied	650	370	Not resistant
	Some	None	0	0	1-2
				8	1-2
				6	1-2
			4	1	1-2
	Air free	Agitated liquid and gas		4.9	4
	Air free	Agitated liquid and gas		1	3
	Some	None	9	5	1-2
	Some	None	5	4	1-2
	Yes	Considerable		2	1-2
	None	Slow circulation	0.4	09	1-2
	None	Slow circulation	7	3	1-2
	Good	By boiling	20	3	1-2
	Good	By boiling	30	4	1-2
	Sat'd with H ₂ S gas	1-2 ft/sec.	8	1	1-2
	With CO ₂ free air	15.3 ft/sec.		Slight gain in weight	1-2
	Some	None	3	0.2	1-2

Corrosive medium	Location of test specimens	Duration of test	Temperature °F	
Calcium hypochlorite, concentrated	Laboratory		60	
Calcium hypochlorite, 0.07%	Laboratory		60	
Carbon dioxide, saturated aqueous solution	Laboratory		60	
Carbon disulphide and water	Inside railroad tank car	240 days	Atmosphere	
Carbon bisulphide, plus carbon tetrachloride, plus Sulphur monochloride, plus, free Sulphur	Suspended from agitator arm in still	339 days		
Carbon tetrachloride	Sump tank, dry cleaning machine	66 days	70-90	
Carbon tetrachloride	Main still-vapour, dry cleaning machine	66 days	160-170	
Carbon tetrachloride	Main still-liquid, dry cleaning machine	66 days	160-170	
Carbon tetrachloride	Main storage tank, dry cleaning machine	98 days	Room	
Carbon tetrachloride vapour containing S ₂ Cl ₂ and CS ₂	Vapour stream above top plate of bubble cap rectification column	133 days	171	
Carbon tetrachloride, crude	Plate 19 of bubble cap rectification column, 3 plates above feed plate	133 days	176	
Carbon tetrachloride, 90%; Benzol, 10%-Kolene solvent	Storage tank	40 days	Room	
Carbon tetrachloride, 90%; Benzol, 10%-Kolene solvent	Bottom of still	38 days	287	
Cellulose acetate 10-15%, Magnesium sulphate 2-5%, Acetic acid 75-80%		133 days	140	
Chlorinated Benzene	Top of still	137 days	280	
Chlorinated solvents, condensate and steam	Condenser	99 days	140-200	
Chromic acid, 3.4% plus Sodium sulphate	Cleaning tank	50 days	Room	
Coal tar (High chloride content)	Fractionating column Top Middle Bottom	154 days 154 days 154 days	390 515 550	
Coke oven gas, raw	In gas stream ahead of final cooler	133 days	150	
Corn gluten and Sulphurous acid	Gluten settler	840 hours	90	
Corn syrup, pH 5.0	Syrup tank	528 hours	140	
Corn syrup	Above liquid level in syrup mixing tank	114 days	170	
Corn syrup	Below liquid level in syrup mixing tank	114 days	170	
Corn: glucose liquor 22° Be, pH 4-4.5	Between plates and side of filter press	100 days	168-180	
Corn, gluten, plus 0.05% Sulphur dioxide	Near middle of gluten settler	77 days	70-90	
Corn sugar-dextrose; first sugar Masseccuite, 40° Be, pH 4 due to HCl	On agitator arm of dextrose crystalliser	70 days	84-120	
Diethanolamine water solution 11-15% containing 10-15 grams H ₂ S per gal.	Laboratory	483 days	228	
Ethyl alcohol, 68% by vol.; Acetone, 30%; Methanol, 21%; balance air	In vapour space above carbon bed in activated carbon absorber	278 hours	69	
Fatty acids; crude split Oleic and Stearic acids	In vapour in fatty acid still	3 weeks	440	
	In liquid in fatty acid still	3 weeks	440	
	Vacuum bubble tower between top tray & scum	2002 hours	425 to 600	

	Aeration	Velocity	Average corrosion rates mils per year		Type Ni-Resist iron preferred
			Cast iron	Ni-Resist iron	
	Some	None	6	0.8	1-2
	Some	None	8	2	1-2
	Some		30	1	1-2
			6.3	2	1-3
	Some	Completely Destroyed		1	1-2
				1	1-2
				0-3	1-2
				1	1-2
				2	1-2
	None	Considerable flow	7	0.5	1-2
	None	Violent	5	0.4	1-2
	None	None	20	0.6	1-2
	None	By boiling	4	2	1-2
	Moderate	Moderate		1.5	2
	None	Some	2	1	1
			90	10	1-2
			90	8	1
	None	Some	200	6	3
	None	Some	13	1	3
	None	Some	6	3	3
	None	Some	28	2	1
			40	5	1-2
			1	0.7	1-2
	In the air	Securely fastened to shell	2	0.4	1-2
	Open to air	Constant	1	0.2	1-2
	Moderate	4 gal./sq. ft./min.	10	3	1-2
	Slight	None	20	5	1-2
	None	7 ft/min.	2	0.6	1-2
	None	50 ft/sec.	17	1.1	1
	Good	Practically none	50	3	1-2
			730	10	2
			790	20	2
	Some		370	20	2

Corrosive medium	Location of test specimens	Duration of test	Temperature °F	
Fatty acids, crude	Vacuum bubble tower between top tray & feed tray	2002 hours	425 to 600	
	Vacuum bubble tower between trays 4 and 5	2002 hours	425 to 600	
Fatty acids, animal	Twitchell saponifer tank	38 days	Boiling	
Fatty acids; concentrated mix from fish oils	Storage tank	130 days	200	
Fatty acid vapours from fish oils	Vapour stream of fatty acid still	210 days	475	
Fertiliser: Ammonium nitrate and phosphate, Potassium chloride, aqua ammonia, 45% salt concentration	Downstream from meter	29 days	107	
Fertiliser, commercial "5-10-15" chemical fertiliser	In contact with damp granules in storage	290 days	Atmosphere	
Fish solubles condensed at a pH of 4.6	Near bottom of worse tank	170 days	90	
Fish solubles condensed at a pH of 4.2	Bottom of work tank	105 days	90	
Furfural, 25% and traces of acetic and formic acids and other organic compounds	Condenser head inlet	317 days	210	
Gasoline, vapour of straight run (63° A.P.I.)	Lower section above y16 tray of stabiliser	6252 hours	375	
Gasoline, straight run (63° A.P.I.)	5' above bottom of reflux accumulator	6252 hours	110	
Gasoline, straight run, with some HCl and H ₂ S	Top tray of bubble tower in topping unit	116 days	250-260	
Gasoline, cracked, with some HCl and H ₂ S	Top tray of bubble tower in Donnelly cracking unit	116 days	400-415	
Gasoline, aviation Dry during major portion of distillation cycle, but steam present from 180-212 °F. Specimens in column during 3 steam out periods totaling 30 hrs; max. temp. 350 °F. Balance of time samples exposed to air at 100 °F average temperature	Base of column below packing in Stedman fractionating column	13 days	225	
Glue, 5%; water, 95%	Cooling tank	10 months Immersed $\frac{1}{3}$ of time, in air the balance.	140-190	
Glutamic acid, crude, pH 5.6	In vapours of evaporator	36 days	158	
Glutamic acid and saturated solution of NaCl, pH 3.2	In liquid in crystalliser	28 days	77	
Glycerine, fed to evaporator	Feed tank	182 days	130	
Glycerine soap lye with 10-12% Glycerine, 13-16% NaCl and H ₂ SO ₄ , mud and water	Alkali treating tank	105 days	185	
Glycerine salt (evaporated spent soap lye); concentrated Glycerine saturated with salt in suspension	In still	648 hours	320	
Glycerine, concentrated, saturated with salt plus salt crystals	In vapour phase attached to head of still	2125 hours	300	
Grapefruit juice	Laboratory	18 hours 3 hours only for C.I.	Boiling	

	Aeration	Velocity	Average corrosion rates mils per year		Type Ni-Resist iron preferred
			Cast iron	Ni-Resist iron	
	Some		390	30	2
	Some		180	10	2
			70	20	2
	None	None	60	8	2
		By vapour flow	140	10	2
	Moderate	200 ft/min	170	7	4
	Some	None	10	3	1-2
	Air free	60 ft/min.	4.9	1	1
	Air free	40 ft/min.	2.7	0.2	1
	Air free	75-100 ft/sec		1.5	1
		95 psi	6	2	1-2
		60 psi. press.	3	2	1-2
	None	Rapid due to bubbling	50	10	1-2
	None	Rapid due to bubbling	2	1	1-2
	Slight	Vapour stream 25 ft/sec.	2	0.6	1-2
	Unknown	None	4	0.04	1-2
	None	Considerable	17	8	1-2
	Yes	Considerable	6	4	1-2
				2	2 Cu-free Ni-Resist
	Some	Some	40	10	2
		Violent	80	10	2
	None	Violent boiling under vacuum of 10 mm. Hg absolute pressure	80	10	2
	None	None	2340	20	1-2

Corrosive medium	Location of test specimens	Duration of test	Temperature °F	
Hydrochloric acid, 5% by vol.	Laboratory		60	
Hydrochloric acid, 10% by vol.	Laboratory		60	
Hydrochloric acid, 25% by vol.	Laboratory		60	
Hydrochloric acid, 1%	Laboratory		Room	
Hydrochloric acid, 2%	Laboratory		68	
Hydrochloric acid, 3.7%	Laboratory		68	
Hydrochloric acid, 5%	Laboratory		Room	
Hydrochloric acid, 20%	Laboratory		Room	
Hydrochloric acid gas made by volatilizing 31.5% Hydrochloric acid Flow of gas is intermittent, 30% passed thru in 1 hour every 3 ¾ hrs. NH ₃ passed thru for short time after HCl passed thru	Hollow shaft leading to carbonizer	37 days	220	
Hydrofluoric acid, 10%	Laboratory	30 days	50-70	
Hydrofluosilicic acid, 6-9%, and Sodium fluosilicate crystals containing 10-12% water	Storage tank and fluosilicate hopper	163 days 135 days in hydrofluosilicic acid, 28 days in sodium fluosilicate	100 in hydrofluosilicic acid, atmosphere in sodium fluosilicate hopper	
Hydrofluosilicic acid, 22% Speed in acid 24 hrs. a day, although high temp. and agitation existed only 8 hours a day. C.I. had to be removed end of 6 days	In Weir box	94 days	145	
Hydrogen sulfide, moist	Laboratory	7 days	200	
Hydrogen sulfide, 98%; balance air and nitrogen	Gas path of extraction unit	188 days	90	
Insecticide: Pesticide solutions used for spraying tomatoes consisting of Marsate wettable powder, Farzate wettable powder, tribasic copper sulfate, Zerlate wettable powder	Spray tank	420 days	60-100	
Margarine	At waterline in margarine tank	38 days	Boiling and atmosphere	
Meat juice extract; acidified extract of animal tissue, pH 4-5, organic solids conc'd from 0.5% to 40%, inorganic salts of Na and K as chlorides and phosphates 0.1% to 5% max. HCl for acidification	Laboratory	129.5 hours	120-180	
Methyl alcohol, crude	Still	1927 hours	160	
Mining: Flue gas from combustion of Ohio strip mine coal-sulphur 2.5-4.5%	Unit air heater	197 days	300	
Monoethanolamine, in scrubbing of CO ₂ from Hydrogen	Stripping tower	100 days	180-220	
Monoethanolamine plus CO ₂ and H ₂ S	Girbitol stripper	270 days	230	
Naphtha, plus 15-30% of a mixture of Oleic, Linoleic and Abietic acids	At bottom of scrubber	196 days	Room to 570	
Naphthalene, crude, plus Sulfuric acid Initial conc'n of acid: 93%, final: 60-75%	Bottom of washer	10 days	185-203	

	Aeration	Velocity	Average corrosion rates mils per year		Type Ni-Resist iron preferred
			Cast iron	Ni-Resist iron	
	Some	None	70	10	1
	Some	None	1220	9	1
	Some	None	1220	20	3
			200	6	1
			880	5	1
			5180	15	1
			672	10	1
			2240	12	1
	Some air enters with HCl		20	10	1
			220	1	1
	Agitated with air	With air	160	6	1
	None	Considerable	5520	4.8	1
			70	10	1
	Good	By gas flow	3	2	1
	None	Mechanical	3	0.8	1
			190	4	2
		Due to evaporation	50	5	1-2
	Away from air	Mild	12	4	1-2
	20%	2000' min.	2.8	0.9	1
	Open to gas		8	4	1-2
	None	Considerable	2	0.2	1-2
	None	None	2	0.2	2
	Negligible	Mechanical agitation	2140	450	Not resistant

Corrosive medium	Location of test specimens	Duration of test	Temperature °F	
Naphthenic acids in heavy distillate from South American petroleum	Between trays 6 and 7 of second fractionating column	59 days	554	
Nickel plating solution	Wood tank	820 hours	75	
Oil, Sour lube (2% Sulphuric acid, 58% Hydrocarbons, 40% water)	Agitator	365 hours	100	
Oil, condensate of light gas, non-condensable gases and steam	Condensate line	1176 hours	90–120	
Oleic acid	Red oil wash tank at water line	38 days	Boiling and atmosphere	
Oleum, 15%	Immersed – Laboratory	30 days	70	
Oleum, 15%	Immersed – Laboratory	7 days	500	
Paper pulp with small amounts of SO ₂ , Cl ₂ , H ₂ SO ₄ , pH 4-4.5	Decker effluent	198 days		
Paper stock with 0.15 g/l HCl and 0.02 g/l free Chlorine	Cylinder mold	91 days		
Paper stock solution, 0.1 g/l free Chlorine, pH 2.3-2.5	Thickener vat	449 days		
Paper: deckered Kraft stock screened and washed, pH 7.9	On agitator shaft of storage chest	98 days	46	
Paper: Kraft digester fumes	Digester gas-offline	75 days	200	
Paper: spent neutral sulphite. Tomahawk liquor	In evaporator liquor	145 hours	134–233	
Paper sulphite pulp, pH 6.5 previously treated with Calcium bisulphite cooking liquor and containing Lignosulphonic acid	Head box	79 days	68	
Paper sulphite pulp, pH 5.5, previously treated with Calcium bisulphite cooking liquor and containing Lignosulphonic acid	Head box of blow pit Oliver washer	82 days	68	
Paper sulphite pulp, pH 7.0, with residual Calcium hypochlorite bleach liquor and Sodium hydroxide	Head box	97 days	68	
Paper: "soft" sulfite stock from the drainer, pH 5.6; consistency 2% Specimens out of the stock 50% of time.	On agitator shaft of stock chest	83 days	47	
Paper: Turpentine from Kraft Pulping (Pacific Northwest). Small amount of Hydrogen sulphide, Methyl mercaptan, Dimethyl sulphide	Turpentine phase of decanter	97 days	150–200	
Paper: groundwood and white water, treated with Cu sulphate, Alum and Chloramine	Under bull screen	101 days	100	
Paper: groundwood stock, consistency ½%	Groundwood screen stock spout, in solution	68 days	102	
Perchloroethylene vapours	Solvent recovery still	64 days	260	
Petroleum: crude oil and H ₂ SO ₄	Crude oil agitator	92 months	Atmosphere	
Petroleum: Coal tar base of Quinoline type, pH 8-9. Impurities-carbon and acridine	Tank	185 days	100–200	
Petroleum: Hydrocarbons containing traces of HCl and H ₂ S	Top head of primary distillation unit	453 days	250	

	Aeration	Velocity	Average corrosion rates mils per year		Type Ni-Resist iron preferred
			Cast iron	Ni-Resist iron	
	None	By flow	8	10	1-2
		None	8	4	1
	None	None	160	20	1
			30	7	1-2
			30	1	2
	None	None	0.1	1.4 Type 1 0.3 Type 3	Type 3 Preferred
	None	None	5	15 Type 1 4 Type 3	Type 3 Preferred
			6	2	1-2
			180	20	1-2
				9	1-2
	Slight	50 ft/min.	6	3	1-2
	Vapours and air mix	Occasionally high	5	0.9	1-2
	Slight- Moderate	3 ft/sec.	67	6.4	1
	Negligible	75 ft/min.	4	2	1-2
	Negligible	25 ft/min.	20	10	1-2
	Negligible	75 ft/min.	10	3	1-2
	Moderate	50 ft/min.	20	7	1-2
	Moderate	Flow rate 10-20 gal hour	2.3	0.8	1
	None	None	20	10	1-2
	Practically none	4-5 ft/sec.	30	10	1-2
	None	None	10	4	1-2
		Some	40	3	1
				0.1	3
	Nil	Rapid	1.5	0.4	2

Corrosive medium	Location of test specimens	Duration of test	Temperature °F	
Petroleum: Hydrocarbon stream containing 45 ppm phenols, 130 ppm chlorides and slight trace of sulphide	Primary column	430 days	250–320	
Petroleum: Ranger low S crude	Above highest baffle below lowest of 10 bubble trays	1701 hours	640	
Petroleum: Overhead from crude oil fractionation, hydrogen sulphide and hydrochloric acid present	Crude distillation unit	128 days	200–300	
Petroleum: Overhead from crude oil fractionation, hydrogen sulphide and hydrochloric acid present	Crude distillation unit	128 days	80–100	
Petroleum: Reduced Redwater crude oil and superheated steam; sulphur compounds and some naphthenic acids present	Vacuum unit	175 days	700	
Petroleum: Sour water containing some light flashed distillate and hydrogen sulphide	Vacuum flasher	309 days	130	
Petroleum: Sodium sulphide and sulphonic acid derivatives	Vapour side of evaporator in vapour and gas zone	84 days	140	
Petroleum: Sour water, hydrogen sulphide and light hydrocarbons	Bottom of debutaniser overhead accumulator	568 days	120	
Phenol, 5%	Laboratory		60	
Phenol, Amyl	Bottom of storage tank in vapours	106 days 106 days	200 200	
Phosphoric acid (tetra), concentrated	Laboratory		Varying	
Phosphoric acid, 80-90%, and oxidising substance	In launder acid from precipitator	7–80 days	200	
Phosphoric acid (tetra), concentrated, 83.5-84.5%, P ₂ O ₄	Laboratory	48 hours	140	
	Laboratory	48 hours	356	
Phosphorus molten	Molten storage	185 days	140	
Pineapple juice	Laboratory	48 hours	188	
Pineapple juice	Laboratory	48 hours	75	
Potassium Aluminium sulphate, 5%	Laboratory		60	
Potassium Aluminium sulphate, 10%	Laboratory		60	
Potassium Aluminium sulphate, .1%	Laboratory		60	
Potassium hydroxide 81%	Laboratory	68 hours	428	
Potassium hydroxide 92%	Laboratory	36 hours	515	
Protein hydrolysate mixture containing hydrochloric acid to a pH of 1.5 + low concentration of SO ₂	Laboratory	84 days	110	
Rosin: wood rosin and its derivatives	Vapour section of still	173 days 52 runs of 8 hours each	700	
Sewage sludge, activated	In aeration tank	481 days		
Sewage fumes, raw and untreated, 100% humidity, some H ₂ S, no Chlorine	In gas chamber	260 days	Atmosphere	
Sewage	Sewage regulation chamber	190 days	Atmosphere	
Smelting: Flue gases from sulphate recovery furnace	Cottrell precipitation	170 days	295	
Smelting: Flue gases from sulphate recovery furnace	C. E. recovery boiler	189 days	310	

	Aeration	Velocity	Average corrosion rates mils per year		Type Ni-Resist iron preferred
			Cast iron	Ni-Resist iron	
		1.2 ft/sec.	1.6	1	1
		170 psi	20	10	1-2
	None	1.3 ft/sec.	3	1.4	1
	None	High agitation	2.6	0.3	1
		Continuous agitation	0.9	0.4	1
	None	Medium	3	0.2	2
	Moderate	High at start	0.4	0.1	1
	Nil	Nil		0.5	1
	Some	None	8	9	2-3
	Moderate	Slight	14	10	1
	Moderate	Slight	5	4	1
	None		*	20	1
			1690	20	1
	None	None	*	1.9	1
	None	None	*	20	1
	None	None	0.6	0.6	1
	Alternate immersion	None	790	70	Not resistant
	Alternate immersion	None	60	10	1-2
	Some	None	6	2	1
	Some	None	30	10	1
	Some	None	4	1	1-2
				10	3
				10	2
	Some	Mild	34	9.5	1
	Good	By steam injection	580	10	1-2
	Some		2	2	1-2
			20	6	1-2
	None	Some	18	5	1
	Moderate	Considerable	1.2	0.8	4
	Moderate	Considerable	2.6	0.3	4

Corrosive medium	Location of test specimens	Duration of test	Temperature °F	
Soap: saponification of fats with Caustic soda and graining with salt and brine	At top of settling cone	106 days	160–212	
Soap: Tallow, acidulated cottonseed and soybean oil soap stocks	Mixing tank	10.5 days	138	
Sodium Bromide, concentrated from 22-47°Be	In boiling tank	265.5 days Tank was alternately full and empty	Boiling	
Sodium carbonate, 5%	Laboratory		60	
Sodium carbonate, 10%	Laboratory		60	
Sodium chloride, saturated, with steam and air Alternately exposed	In graining pan	30 days	200	
Sodium chloride, saturated	In salt grainer	60 days	180	
Sodium chloride, saturated brine and salt cake	In Oliver filter	145 days	200	
Sodium chloride	Salt brine tank	180 days	50	
Sodium chloride, natural brine feed	Storage tank	221 days	80	
Sodium chloride, 14% NaCl, 16.7% CaCl ₂ , 3.4% MgCl ₂	Salt settler	215 days	157	
Sodium chloride, 14% NaCl, 16.7% CaCl ₂ , 3.4% MgCl ₂	Hot end of brine heater	215 days	160	
Sodium chloride, 45% NaCl, 18% CaCl ₂ , 3.2% MgCl ₂	Filter feed tank	215 days	130	
Sodium chloride Bittern, 9%, NaCl, 22% CaCl ₂ , 5% MgCl ₂	Settler	221 days	128	
Sodium chloride Bittern, 6% NaCl, 18% CaCl ₂ , 10% MgCl ₂	Heater	365 days	175	
Sodium and Potassium chlorides, saturated solution	In heating agitator – half immersed	31 days	120	
Sodium chloride, 18%, plus residual soap and .03% total, 0.003% free	In trough of filter press	65 days	140	
Sodium chloride brine plus sl. impurities of CaCO ₃ , CaSO ₄ , & Na ₂ SO ₄ pH 9.5	In vacuum evaporator A. Above liquid	55 days	215	
	B. Below liquid	55 days	215	
Sodium chloride brine up to 50%, plus oxidising materials from products of combustion of gas flame	In salt evaporator	329 hours	200	
Sodium chlorite, 0.5%, Calcium hypochlorite, dried chlorination with added sulfuric acid to adjust pH to 4.5-34.3 hrs. to 0.5% Sodium chlorite 138 hrs. to seralion-571.7 hrs. to combined chlorination and hypochlorite treatments	In Bellmer bleach	31 days	97	
Sodium chlorite: 1% Caustic soda and 0.02% Textone Actual boiling time about 12 hrs. day, remainder of time consumed in cooling and reloading	Under grating of bleaching keir	23 days	215	
Sodium cyanide solution for heavy metals recovery	In overflow tank	60 days	136.4	
Sodium cyanide solution with Sodium chloride	In solution discharge from Traylor coolers	30 days	154	
Sodium cyanide 10 oz./gal. plus Sodium hydroxide 10 oz./gal.	In plating tank	49 days	100–110	

	Aeration	Velocity	Average corrosion rates mils per year		Type Ni-Resist iron preferred
			Cast iron	Ni-Resist iron	
	Some air in steam	By live steam	10	0.1	2-3
	Air free	50'/min.	3.9	0.9	1
			30	3	1-2
	Some	None	No loss	No loss	1-2
	Some	None	No loss	No loss	1-2
			70	5	1-2
			2	0.4	1-2
			20	2	1-2
	Considerable	Some	10	3	1
	Moderate	Some	2	1	1
	None	Some	21	3	1
	None	4 ft/sec.	26	3	1
	Moderate	Some	13	3	1
	Moderate	Some	33	4	1
	None	1500 gpm		2.5	1
	Good	500" min. (theoretical)	20	3	1-2
	Good	Good	70	1	1-2
	None	Considerable	72	0.2	1-2
	None	Considerable	13	1	1-2
	Some due to excess air entrained with gases	Considerable due to combustion gases passing thru	240	20	1-2
	For ¼ of timer	60 ft/min.	10	7	1
	None	Some	7	0.1	1-2
	Slight	By flow	2	0.3	1-2
	Good	180 gal. min.	0.9	0.2	1-2
		Caused by work suspended in bath	2	3	1-2

Corrosive medium	Location of test specimens	Duration of test	Temperature °F	
Sodium hydroxide 30% plus heavy concentration of suspended salt	Salt tank	82 days	180	
Sodium hydroxide, 50%	In distributor box-to settler	32 days	Hot	
Sodium hydroxide, 50%,	In evaporator	38 days	Hot	
Sodium hydroxide, 70% 125 hrs. in 70% caustic, remainder time in 50%	In high concentration evaporator	94 days	Hot	
Sugar (beet) diffusion juice in processing; pH 6.8; purity 86.1; Brix 12.5	In measuring tank	87 days	103	
Sulphate black liquor	Under screen plates in diffuser	349 days		
Sulphate black liquor	In receiving tank	90 days	156	
Sulphate black liquor	In storage tank	92 days	195	
Sulphate black liquor	In storage tank	39 days	200	
Sulphate black liquor	In secondary washer	32 days	137	
Sulphate green liquor	In distribution box	60 days	200	
Sulphonated animal and vegetable oils made alternately acid with 93% H ₂ SO ₄ , and alkaline with 10%, caustic	In neutralisation and wash tank	60 days	104	
Sulphonated oil; mixture of animal and vegetable oils with 93% H ₂ SO ₄	In sulphonator tank	70 days	77–104	
Sulfonated oils with 66°Be H ₂ SO ₄ , followed by washing with Glauber's Salt and neutralization with Caustic soda, 37 sulfonations of castor oil, 2 sulfonations tea seed oil, 1 sulfonation of olive oil. Figures = in./100 batches	In sulphonator	40 batches (1 year)	212	
Sulphonated oils with dilute H ₂ SO ₄	In wash tank	40 days	104	
Sulphur, molten	Laboratory	20 hours	260	
Sulfur, molten Partial immersion	Laboratory	20 hours	260	
Sulphur, molten	Laboratory	4 days	260	
	Laboratory	4 days	500	
Sulphur, molten	Laboratory	2 days	835	
Sulphur, molten, plus air and moisture	In pipeline of a sulphur mine	11 days	305	
Sulphur chloride vapours, 98% S ₂ Cl ₂	Below bottom prate of bubble cap column	133 days	257	
Sulphur chloride, 98.3%; Carbon Tetrachloride, 0.13%; Iron as FeCl ₂ 0.1%	In reboiler for rectification column	133 days	280	
Sulphuric acid, 5%	Laboratory	20 hours	86	
Sulphuric acid, 10%	Laboratory	20 hours	86	
Sulphuric acid, 80%	Laboratory	20 hours	86	
	Laboratory	20 hours	86	
Sulphuric acid, 96%	Laboratory	25 days	Room	
Sulfuric acid and oils Ins./100 batches	In oil sulphonator	8 batches		
Sulphuric acid, 25% and acid sludge	In discharge line	1326 hours	140	

	Aeration	Velocity	Average corrosion rates mils per year		Type Ni-Resist iron preferred
			Cast iron	Ni-Resist iron	
	Moderate	Moderate	6.3	0.1	4
			20	4	2-3
			30	6	2-3
			40	20	2-3
	Alternately	Intermittent gentle flow	9	10	1-2
	None	None	10	1	1-2
	None	5-10 ft/min.	20		1-2
	Practically none	None	10	8	1-2
	In air part of time	Practically none	20	10	1-2
	Practically none	Practically none	20	1	1-2
	Slight	Fairly rapid flow	30	6	1-2
	None	Commercial practice is to stir	190	5	1
	None	Commercial practice is to stir	180	5	1
	Good	Good	*	5	1
		Medium	40	20	1
	Partial admission of air	None	20	20	1
	Partial admission of air	None	8	7	1
	None	None	0.8	5	1
	None	None	30	30	1
	None	None	400	590	Not resistant
	Yes	Violent	55	13	1
	None, 3-5u pressure	0.5 ft/sec. vapour velocity	160	1	2-3
	None	By boiling	130	2	2-3
	None	None	*	20	1
	None	None	*	20	1
	None	None		20	1
	None	15.5 ft/min.		20	1
	None	None	4	5	1
		Stirred	230	3	1
		Forced flow	Completely destroyed	8	1

Corrosive medium	Location of test specimens	Duration of test	Temperature °F	
Sulphuric acid, 72%, Polymer Gasoline, Butane and Butylenes	In gasoline tower	237 days	175	
Syrup, soft; the mother liquor separated from crystallised soft sugar	In "soft syrup" tank	217 days	140	
Tanning solutions: Tannin extract from chestnut wood	In evaporator	24 days	212	
Tar (coal)	At top of still	5 months	700	
	At centre of still	5 months	700	
	At bottom of still	5 months	700	
Tar acid (coal)	In vapours in still	1248 hours	260	
	In liquid in still	1248 hours	260	
Tar (coal)	In vapours in still	1052 hours	550	
	In liquid in still	1052 hours	600	
Tar (coal), complex organic constituents of	In still	10 days		
Tomato juice	Laboratory		125	
Vinegar syrup, sweet, with 2% Acetic acid, 3% Sodium chloride, 35% sugar	In kettle	1 hour, 55 minutes	Boiling	
Vinegar, sweet	Storage tank	40 days	63–212	
Water: acid, mine, containing iron and copper salts leached from sulphide ore	Mine shaft	187 days	Atmosphere	
Water, brackish East River, N.Y.C.	Water box of steam power plant	334 days	54	
Water, brackish Harlem River, N.Y.C.	Water box of steam power plant	197 days	55	
Water, cooling tower at pH 8.0-8.5 as obtained from Syracuse water supply treated with algicide, oakite sanitiser #1 and aerated	Cooling tower basin	232 days	45–88	
Water, distilled	Laboratory		60	
Water, fresh, pH 8.5 (185 ppm CaCO ₂)	In discharge from cooling tower	23 days	85	
Water, salt, from oil wells	In saltwater pit	217 days	60	
Water, sea	On screens in rotating screen house	394 days	Atmosphere	
Water, sea	Velocity testing apparatus	60 days	86.	
Water, sea	Intake flume	740 days	Atmosphere	
Water, sea	In condenser	58 days	158–176	
Water, steep (0.070% H ₂ SO ₃)	In germ separator	184 days		
Water, steep, with 0.05% CO ₂ and 0.5-1.0% Lactic acid, pH 3.5-4.5	In steep water evaporator	40 days	150	
Water, steep, vapours with 0.05% SO ₂ and 0.5-1.0% Lactic acid, pH 3.5-4.5	In steep water evaporator	24 days	160	
Water, steep	In circulating tank	107 days	125–135	
Wheat starch, water, SO ₂ and Dowicide, pH varied from 2.2 to 3.8	Drum dryer	68 days	320–340	

	Aeration	Velocity	Average corrosion rates mils per year		Type Ni-Resist iron preferred
			Cast iron	Ni-Resist iron	
		Due to bubble caps	70	20	1
	Good	1550 gals/ hour	5	0.1	1-2
		Continual ebullition	220	20	1-2
			10	9	1-2
			10	9	1-2
			8	6	1-2
	In vapours	None	0.8	0.004	1-2
	None	None	40	5	1-2
	In vapours	None	2	0.4	1-2
	None	None	3	0.8	1-2
	430	Good	80	9	1-2
		Some	110	20	2
			340	0.15	2
				0.006	2
			6	1	2
	Yes	High	10	2	1
	Yes	0.8 1/sec.	10	4	1
	Extensive	1 ft/sec.	42	1 3	1
	Some	None	10	0.6	1-2
	80% sat'd	Some	30	20	1-2
	Slight	By flow	20	1	1-2
	Screens moving in and out of water	Good	10	2	1-2
	Considerable	27 ft/sec.	176	8	1
	Considerable	5 ft/sec.	50	2	2
		By flow	40	10	1-2
			30	5	1-2
	Moderate	By boiling	70	20	1-2
	Liquor going to pan sat'd with air	20-50 ft/sec.	40	10	1-2
	None	None	10	5	1-2
	Slight	Slight	45	14	1

Corrosive medium	Location of test specimens	Duration of test	Temperature °F	
Whiskey slop, thick	In tank	104 days, 6 days/wk 89 days actual operation	Near boiling	
Whiskey slop, thin	In tank	104 days, 6 days/wk 89 days actual operation	Near boiling	
Whiskey mash	In beer still	103 days 6 days /wk 88 days actual operation		
Whiskey mash	In open fermenter	103 days	65–75	
Whiskey slop, thin	In tank	3 months	150–220	
Whiskey slop, thin	At outlet from still in screening unit	3 months	210–225	
Whiskey slop, thin; concentrated 25% solids, 5% Lactic acid	In reserve tank	90 days	220	
Whiskey slop, thin	In settling tank	3 months	Varying	
Whiskey slop	In slop outlet	3 months	Hot	
Whiskey slop, thin	In settling tank	1 month		
Whiskey slop, thin	In tank	5 weeks		
Wine, sherry	In cooker	7–15 days	110	
Wine, sherry	In cooker	7–15 days	135	
Zinc, molten	Laboratory; half immersed	36 hours	925–950	
Zinc; return electrolyte from electrolytic cells	In acid heating cell	7 days	140	
Zinc chloride, 66%, and 20% Ammonium chloride	Laboratory	2 hours	182–204	
Zinc chloride, 85%, and gasoline vapours	In Lachman tower		380	
Zinc chloride, 80%, and Sodium dichromate, 20%	In salt cylinder	144 days	140	

	Aeration	Velocity	Average corrosion rates mils per year		Type Ni-Resist iron preferred
			Cast iron	Ni-Resist iron	
	None	None	50	10	1-2
	None	None	10	7	1-2
	Exposed in still air	Due to movement of liquid and vapours	110	20	1-2
	None	None	140	3	1-2
	Aerated as passed over screen but not in tank		20	4	1-2
	Complete	130 ft/min.	10	7	1-2
			20	2	1-2
	None	None	20	4	1-2
	None	None	20	2	1-2
	None	None	30	4	1-2
	None	None	40	2	1-2
		Wine circulated	Ordinarily not satisfactory	2	2
			Ordinarily not satisfactory	8	2
			42700	23900	Not resistant
	None	50 gal./min	Completely dissolved	380	Not resistant
	None	None	680	20	1-2
			6	1	1-2
	None	None	4	0.3	1-2

SELECTED BIBLIOGRAPHY

The following documents, published by the Nickel Institute, provide further detail of some of the subject matter covered in this publication:

- 242 Machining and Grinding Ni-Resist and Ductile Ni-Resist
- 4077 Nickel SG-Iron - Engineering Properties
- 4421 Welding of Flake and Spheroidal Graphite Ni-Resist Castings
- 10018 Influence of carbide content on the stress corrosion cracking of Ni-Resist cast iron in warm seawater





knowledge for a brighter future

Nickel Institute

communications@nickelinstitute.org

www.nickelinstitute.org

Published 2022
